

Joint Improvised Explosive Device Defeat Organization (JIEDDO):

Tactical Successes Mired in Organizational Chaos;

Roadblock in the Counter-IED Fight

**LTC Richard F. Ellis, USA
Maj Richard D. Rogers, USAF
LCDR Bryan M. Cochran, USN**

**Joint Forces Staff College
Joint and Combined Warfighting School - Intermediate
Class # 07-02
13 March 2007**

**Faculty Advisor: LtCol Jeff Kersten, USAF
Seminar #06**

Report Documentation Page

Form Approved
OMB No. 0704-0188

Public reporting burden for the collection of information is estimated to average 1 hour per response, including the time for reviewing instructions, searching existing data sources, gathering and maintaining the data needed, and completing and reviewing the collection of information. Send comments regarding this burden estimate or any other aspect of this collection of information, including suggestions for reducing this burden, to Washington Headquarters Services, Directorate for Information Operations and Reports, 1215 Jefferson Davis Highway, Suite 1204, Arlington VA 22202-4302. Respondents should be aware that notwithstanding any other provision of law, no person shall be subject to a penalty for failing to comply with a collection of information if it does not display a currently valid OMB control number.

1. REPORT DATE 13 MAR 2007		2. REPORT TYPE		3. DATES COVERED 00-00-2007 to 00-00-2007	
4. TITLE AND SUBTITLE Joint Improvised Explosive Device Defeat Organization (JIEDDO): Tactical Successes Mired in Organizational Chaos; Roadblock in the Counter-IED Fight				5a. CONTRACT NUMBER	
				5b. GRANT NUMBER	
				5c. PROGRAM ELEMENT NUMBER	
6. AUTHOR(S)				5d. PROJECT NUMBER	
				5e. TASK NUMBER	
				5f. WORK UNIT NUMBER	
7. PERFORMING ORGANIZATION NAME(S) AND ADDRESS(ES) Joint Forces Staff College, 7800 Hampton Blvd, Norfolk, VA, 23511-1702				8. PERFORMING ORGANIZATION REPORT NUMBER	
9. SPONSORING/MONITORING AGENCY NAME(S) AND ADDRESS(ES)				10. SPONSOR/MONITOR'S ACRONYM(S)	
				11. SPONSOR/MONITOR'S REPORT NUMBER(S)	
12. DISTRIBUTION/AVAILABILITY STATEMENT Approved for public release; distribution unlimited					
13. SUPPLEMENTARY NOTES					
14. ABSTRACT					
15. SUBJECT TERMS					
16. SECURITY CLASSIFICATION OF:			17. LIMITATION OF ABSTRACT Same as Report (SAR)	18. NUMBER OF PAGES 19	19a. NAME OF RESPONSIBLE PERSON
a. REPORT unclassified	b. ABSTRACT unclassified	c. THIS PAGE unclassified			

The United States Department of Defense (DoD) estimates that Improvised Explosive Devices (IEDs) are responsible for almost 50% of the casualties (both mortal and injured) sustained in Iraq and nearly 30% in Afghanistan since the start of combat operations.¹ Furthermore, in Operation Iraqi Freedom (OIF) and Iraqi Enduring Freedom (OEF), deaths from IEDs have steadily increased since the cessation of major combat operations in 2003.²

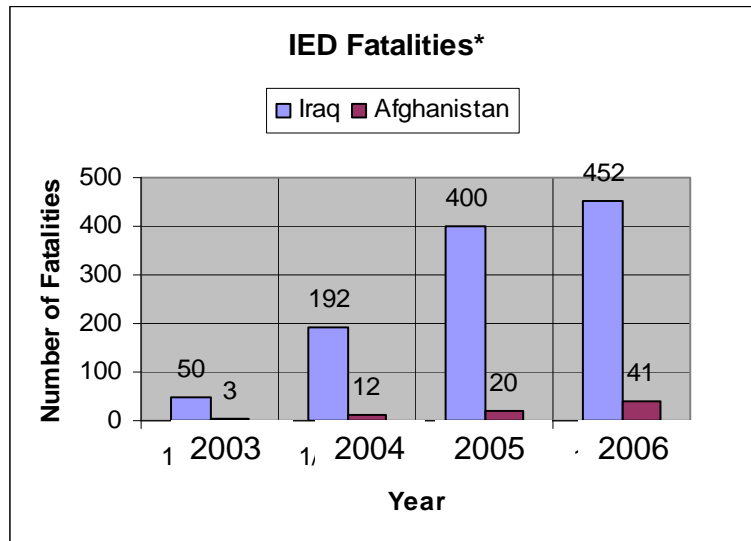

*Afghanistan IED Data from 2001/2002 not included due to statistical insignificance

(Figure 2. IED Fatalities from 2003-2006)

As a result of the staggering losses inflicted by these devices, defeating this terrorist tactic has become a top priority for the DoD. The American public is swayed by many things, but none more convincingly than nightly news reports of U.S. casualties from IEDs in Iraq and Afghanistan. In order to win the Global War On Terror (GWOT), bureaucrats and warriors alike must harness the nation’s ingenuity and resources to defeat this terrorist weapon, which threatens to diminish national will in the fight for freedom.

Given the magnitude of the IED threat, the Secretary of Defense created the Joint IED Defeat Organization (JIEDDO) to address this problem in February, 2006. JIEDDO is chartered

¹ Congressional Research Service Report for Congress, Order Code RS22330, 25 Sep 06.

² icasualties.org. <<http://icasualties.org/oif/IED.aspx>>

to “focus (lead, advocate, coordinate) all DoD actions in support of the Combatant Commanders’ and their respective Joint Task Forces’ efforts to defeat IEDs as weapons of strategic influence.”³

However, JIEDDO, as an organization, possesses neither the structure nor the authority to effectively prosecute the war against IEDs. As a large, bureaucratic organization rooted in the technological approach to defeating IEDs, JIEDDO lacks the agility to quickly react to a changing enemy and has no legal authority to compel other DoD entities to act. This paper analyzes JIEDDO by reviewing its origins, examining its current structure and authority, and identifying recommendations that may improve its ability to defeat IEDs.

The Origin of JIEDDO

As the major combat phase of the initial run to Baghdad subsided in the summer of 2003, the United States began to see a different enemy emerge. This was not the once-touted Republican Guard of the Iraqi Army, a force which our military doctrine had prepared us to defeat; this enemy was far more difficult to define. In its infancy, the *insurgency*, as it was labeled throughout the media, utilized terrorist and asymmetric tactics designed to overthrow the legitimate Iraqi government and demoralize the population. Rather than use large-scale military operations, the insurgents’ methods challenged the Iraqi government’s ability to provide security to its population and restore essential services to Iraqi cities; their goal was to start a protracted war to defeat the will of their enemy, the U.S. Government. One of the tactics they employed to their advantage was IED attacks against US forces—mostly ill-prepared and unprotected supply convoys. The ground force in Iraq had not foreseen this threat during initial planning for Operation Iraqi Freedom. In response, the U.S. Army decided to put additional effort against the growing problem, but still treated the situation as a “terrorist tactic” that could be overcome with

³ DoD Directive 2000.19E, “Joint IED Defeat Organization,” 14 Feb 06.

new training and techniques in theater as opposed to a strategic threat that required harnessing the skills and resources of the entire nation.

The number and ferocity of IED attacks steadily increased during the summer of 2003. As a result, in October 2003, the Commander of U.S. Central Command, General John Abizaid, wrote an executive memo to Secretary of Defense, Donald Rumsfeld, and the Chairman of the Joint Chiefs of Staff, General Richard Myers, describing IEDs as the “number one killer of American troops” and “asked for a ‘Manhattan-like Project’ to help with the effort.”⁴ In response, the Deputy Chief of Staff G-3 for the US Army, Lieutenant General Cody, formed a task force of 12 people to combat this new insurgent tactic. However in July 2004, as insurgents’ attacks changed and IED casualties mounted, Deputy Secretary of Defense Paul Wolfowitz approved the establishment of an Army-led Joint Integrated Process Team (IPT) to harness the expertise of *all* military services on this issue.⁵ This team continued its work over the next year and scored several victories against the IED threat—namely the use of vehicle and personal armor and explosive ordnance disposal robots. At the same time, the Navy, Air Force and Marine Corps established teams to engineer IED defeat mechanisms for their indigenous platforms. These efforts, while inventive at times, frequently duplicated effort and squandered scarce DoD resources. As a result, the different Services fielded successful prototypes that not only lacked interoperability on the battlefield, but often interfered with other military systems. As had been the norm throughout much of the Cold War, the competition for resources led the Services to develop their own initiatives, which precluded them from jointly acquiring IED defeat solutions.

This fact was not lost on senior DoD leadership, or the media. In June 2005, acting Deputy Secretary of Defense Gordon England, issued DoD Directive 2000.19D to establish the

⁴ John Barry, Michael Hastings and Evan Thomas. “Iraq’s Real WMD.” *Newsweek*. 27 March 2006 Issue

⁵ LTG James J. Lovelace, USA, and BG Joseph L. Votel, USA. The Asymmetric Warfare Group: Closing the Capability Gaps. *Army Magazine*. March 2004.

Joint IED Defeat Task Force (JIED TF), focusing the entire Defense Department's efforts against defeating IEDs.⁶ To further elevate the status of the JIED TF, Secretary of Defense Donald Rumsfeld assigned retired Army General Montgomery Meigs to lead the JIED TF in December 2005.⁷ To provide permanent status to the task force, Secretary England issued a memorandum on 18 January 2006 elevating it to the Joint IED Defeat Organization.⁸ He then codified the organization into department policy with the issuance of DoD Directive 2000.19E in February 2006. The rapid expansion of a small (12-person, single Service) task force into a large (four-star led, multi-service, multi-agency and multi-national) DoD organization in little more than two years presents challenges that must be overcome. This growth produced an organizational structure that clearly outgrew the original intent of the small Army task force. Furthermore, the authority conveyed to this new organization in DoD Directive 2000.19E is not commensurate with the responsibilities directed by the Secretary of Defense.

JIEDDO Structure and Authority

As of September 2006, JIEDDO employed 360 personnel and managed a budget that exceeded \$3 billion.⁹ The dramatic rise in personnel and budget creates a bureaucracy that the original 12-person task force never faced. Acknowledging this challenge, the Senate Appropriations Committee directed the Government Accountability Office (GAO) to conduct a thorough examination of among other things, JIEDDO's "organizational structure and the duties and responsibilities of JIEDDO personnel and associated contractors."¹⁰ The GAO report will not be completed prior to submission of this paper, but clearly these concerns have attracted the attention of Congress.

⁶ DoD Directive 2000.19D, pp. 1.

⁷ DoD News Release, No 1260-05, 5 Dec 05, <http://www.defenselink.mil/Releases/Release.aspx?ReleaseID=9137>

⁸ Miles, Donna. "DoD Taps Industry Know-how in Ongoing Counter-IED Efforts." Armed Forces Press Service, 24 Jan 06.

⁹ McGuire, Nancy. Military Services Bring it All Together to Counter IEDs. Office of Naval Research. www.onr.navy.mil. p. 1 of 4.

¹⁰ Senate Report 109-292. Department of Defense Appropriations Bill, 2007. 25 July 2006.

Despite JIEDDO's rapid growth and elevation to Office of the Secretary of Defense (OSD)-level, the organization largely remains focused on fielding technical equipment, developing tactical solutions, and providing training at the battlefield level. JIEDDO reflects this approach in its motto, "Defeat the network—Defeat the device—Train the force."¹¹ However, just as the organization has grown, so too has its scope and responsibility. To realize this expansion of its original mission, JIEDDO must be structured in such a way and have the proper authority to:

1. React quickly to a changing environment;
2. Accelerate the normal DoD acquisition process;
3. Implement an overarching strategy;
4. Compel others in the Department to act in accordance with its objectives.

Structure

Any undergraduate business major can tell you that the larger an organization gets, the less agile it becomes. In the same respect, larger organizations tend to have multiple layers of management that impede communication and slow the decision-making process. Very few organizations, with the exception of ones comprised of flat structures, can maintain innovative and creative thinking at the same pace as smaller outfits. This relationship of decreasing agility to increasing size is natural in large organizations, and according to noted organizational theorists Cohen and Klepper, is "a trait which tends to grow in proportion to the organization itself."¹² In essence, the larger and faster an organization grows, the less likely it is to be able to quickly adapt to its changing environment with innovative solutions or products—a trait JIEDDO must possess to successfully defeat IEDs. A large organization creates additional

¹¹ Joint IED Defeat Organization. 16 Nov 2006. Presentation, *US Army Training Transformation Council of Colonels*, (PowerPoint Slides FOUO). Briefing posted in *Army Knowledge Online* shared folder.

¹² Cohen, Wesley M. and Klepper, Steven; "A Reprise of Size and R&D," *The Economic Journal*, July 1996, pp 325-351.

bureaucracy—staff and overhead—which consumes a leader’s time with mundane day-to-day operations detracting from his ability to inspire creative solutions.

Additionally, not only is JIEDDO a large bureaucracy, it is still built around a technical solution approach focused on research and development, testing, and fielding the elusive “silver bullet” to defeat IEDs. By doing so, the organization overly relies on technology to defeat an adaptive enemy who quickly learns how to overcome our latest countermeasures. General Abizaid highlighted this fact when complaining to members of JIEDDO, “its (JIEDDO) emphasis on multi-million dollar contracts to develop high-tech sensing equipment has been ineffective at curbing attacks by homemade bombs.”¹³ Furthermore, a recent Pentagon report cited, “the response to the IED has been primarily to increase force protection by emphasizing technical solutions which have proven insufficient.”¹⁴ JIEDDO’s dependence on fielding “widgets” forces it to immerse itself into the cumbersome DoD acquisition process. This process is difficult to navigate even for small organizations within DoD. The fact that JIEDDO is a bureaucracy with a large budget simply exacerbates the situation. JIEDDO is simply too big to remain as agile as it needs to be.

However, agility and speed is exactly what an organization like JIEDDO *must* have in order to stay one step ahead of a thinking enemy that constantly adapts its methods of attack. The average time for a normal DoD acquisition program to progress from determining a mission need to actually fielding a system is approximately 84 to 144 months.¹⁵ The average timeline for the enemy to change his tactics can be days or even hours, depending upon the circumstances and his desire to adapt. How is a large government organization like JIEDDO supposed to compress that timeline and compel the various parts of DoD to meet this kind of schedule?

¹³ Bender, Bryan. “Panel on Iraq bombings grows to \$3b effort Critics say it has been ineffective.” *The Boston Globe*, June 25, 2006.

¹⁴ Ibid.

¹⁵ Chew, James S.B. “Commercial Best Practices and the DoD Acquisition Process,” *Acquisition Review Quarterly*, Spring 1997, pp. 219.

Nominally, one would expect them to circumvent the normal acquisition process by transferring “seed money” directly to a Service for concept development and then requiring it to budget for procurement after device fielding. While this strategy ensures that critical capabilities reach the field in an expeditious manner, it fails to provide a long-term sustainment plan. In order to ensure that these prototypes are properly included in the DoD Planning, Programming, Budgeting and Execution (PPBE) process, the Director of JIEDDO is responsible for “develop(ing) transition plans for proven Joint IED Defeat initiatives into DoD programs of record for further sustainment and integration.”¹⁶ JIEDDO should provide a DoD-level acquisition strategy, based on Regional Combatant Commander (RCC) priorities, that directs Service execution of material solutions. A joint acquisition plan for defeating IEDs would ensure unity of effort when the Services budget for their individual programs.

However, by focusing on the short-term, technical solution approach, JIEDDO created a structure that short-changed its responsibility to guide the entire DoD effort to defeat IEDs. A clear, overarching strategy to focus DoD energy and guide RCCs in their areas of responsibility (AOR) appears to be lacking. Instead, JIEDDO rooted its strategic efforts—Defeat the Network—in still more technical concepts such as persistent surveillance; technical, biometric, and internet exploitations; information operations; counter-bomber targeting; and removal of explosive remnants of war.¹⁷ A closer look at the JIEDDO structure offers an explanation for this oversight in strategic thought.

The staff organization does not follow a traditional J-code staff as one might expect. Rather, the current departments are: Technology, Intelligence, Operational Research Systems Analysis (ORSA), Operations, STRATCOM, Requirements Integration, and Resource Management (*Figure 2*). A J-5 equivalent, or a traditional planning staff, does not appear to

¹⁶ DoD Directive 2000.19E, pp. 3.

¹⁷ Joint IED Defeat Organization. 16 Nov 2006. Presentation, *US Army Training Transformation Council of Colonels*, (PowerPoint Slides FOUO). Briefing posted in *Army Knowledge Online* shared folder.

exist even though DoD Directive 2000.19E specifically directs JIEDDO to “develop, publish, and update the DoD IED Defeat Strategic Plan to provide an overarching framework to guide the DoD Components’ long-term counter-IED efforts.”¹⁸ As a result, JIEDDO strategic planning appears to be an afterthought rather than a deliberate activity, and the organization has not established an office to perform that task. Consequently, RCCs are left to conduct counter-IED planning for their AORs without clear strategic guidance. Although the Directive specifically requires RCCs to formulate their own IED defeat plans without DoD level guidance, these plans fail to integrate or synchronize effort across AOR boundaries, whereas defeating IEDs is a global problem.

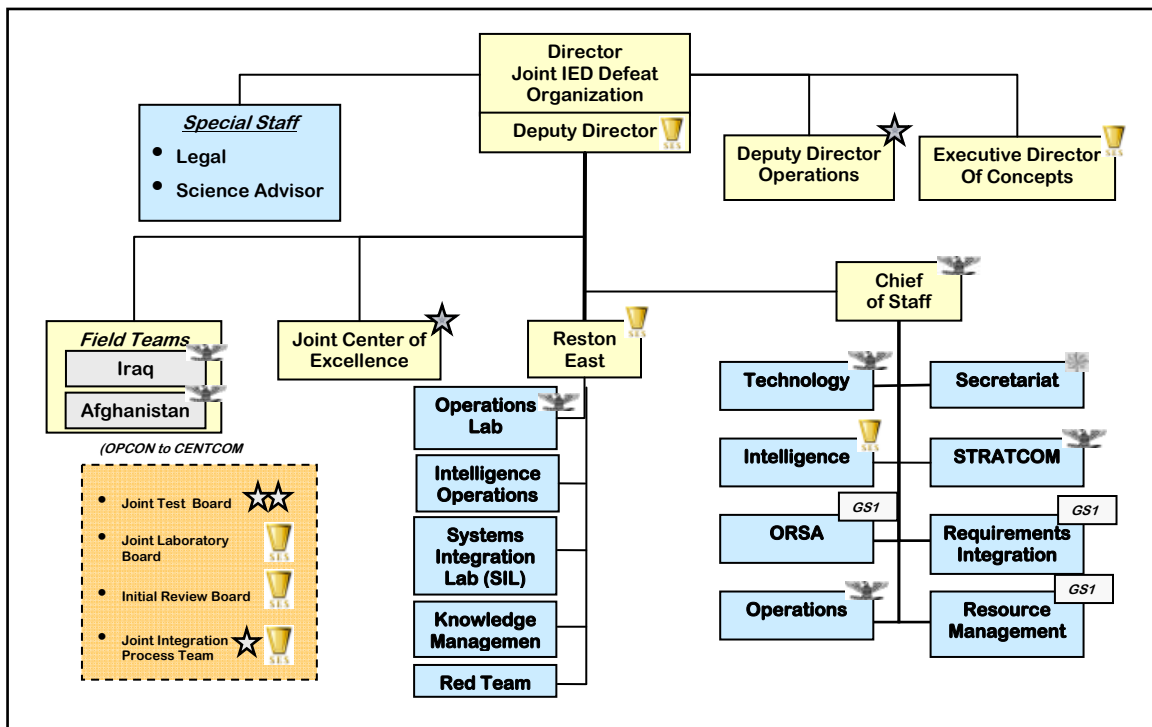

Figure 2: JIEDDO Organization Chart

The lack of a strategic planning staff in the JIEDDO structure stems from its origins as a small, technological innovation center focused on developing a high-tech force protection solution to defeat IEDs. However, as Directive 2000.19E illustrates, JIEDDO’s mandate now

¹⁸ DoD Directive 2000.19E, p.4.

includes broader, strategic responsibilities. Thus, although JIEDDO is obviously structured to develop innovative solutions in its approach to defeating IEDs, it must also provide overarching policy and guidance to ensure seamless integration of those capabilities across the DoD. To accomplish this objective, JIEDDO must dedicate resources to the task or consider a new structure that leverages existing capabilities within the DoD.

Realignment of JIEDDO under a functional combatant commander such as USJFCOM would streamline the counter-IED fight. Moreover, USJFCOM provides a natural fit for JIEDDO's current planning function responsibilities. As General Pace, Chairman of the Joint Chiefs of Staff, stated in a memorandum for the Chiefs of the Services; Commanders of the Combatant Commands; and Directors, Joint Staff Directorates, "USJFCOM will plan, design, execute, and assess a relevant and credible joint warfighting experimentation program on concepts, capabilities, and prototypes derived primarily from the Joint Concepts family."¹⁹ The USJFCOM staff with support from JIEDDO would conduct the planning functions to develop an overarching strategy for implementation across AOR boundaries. Furthermore, the JIEDDO staff would gain the freedom to pursue innovative IED solutions.

Shifting JIEDDO to a functional combatant commander such as USJFCOM not only addresses the structural issues facing JIEDDO, but also provides a solution to the challenges facing its authority. While JIEDDO possesses budgetary authority for counter-IED programs, it does not have the ability to compel other DoD organizations or Combatant Commanders to act. However, this authority is precisely what JIEDDO requires in order to effectively wage the counter-IED war. Realignment of JIEDDO under USJFCOM would provide the Combatant Command (COCOM) authority JIEDDO requires.

¹⁹ GEN Peter Pace, USMC. Memorandum for Chiefs of the Services, Commanders of the Combatant Commands, Directors, Joint Staff Directorates. Subject: Joint Experimentation (JE) Guidance for FY 2006 and FY 2007. 9 January 2006.

Authority

A closer examination of the establishing document for JIEDDO reveals that it is chartered with wide-ranging responsibilities from “rapidly acquiring equipment to counter known...IED threats” to “assisting combatant commanders with understanding the IED threat.”²⁰ However, the authority granted to JIEDDO by DoD Directive 2000.19E stands in stark contrast to the broad scope of responsibility assigned to the organization. Furthermore, JIEDDO’s limited authority prevents it from compelling other organizations to act or even participate in its efforts.

For example, according to DoD Directive 2000.19E, the Director, JIEDDO, shall “integrate all IED Defeat solutions throughout DoD.”²¹ This requirement implies the need to reach across Service and Agency boundaries to ensure that technical solutions are compatible with existing platforms and interoperable across the DoD. In order to accomplish this task, however, the Director of JIEDDO must have some acquisition authority over the traditional Services’ programs and budget. But the only authority granted to him is to “communicate with the heads of DoD Components.”²² In essence, the Director of JIEDDO can make his case to the Services and RCCs, but has no direct control over program execution. The Services retain budget authority for program management and the RCCs prioritize their IED requirements.

In the same respect, JIEDDO is responsible for developing a strategic plan and providing overarching guidance as a framework for the rest of the DoD Components in their IED Defeat efforts. This plan is supposed to form the foundation for other Components’ regional specific plans. In order to accomplish this objective, JIEDDO must have a planning staff and authority to implement this plan throughout DoD. However, JIEDDO’s authority is mostly limited to coordination and communication with other agencies. While this authority provides an

²⁰ DoD Directive 2000.19E. p. 4.

²¹ Ibid, p. 3.

²² DoD Directive 2000.19E, p. 11.

opportunity to exchange ideas, it does not enable JIEDDO to compel DoD components to follow the published plan.

In fact, doctrinally speaking, coordinating authority is a “consultation relationship, not an authority through which command may be exercised.”²³ JIEDDO’s responsibility requires a term similar to “synchronize,” which USSOCOM was granted in the Unified Command Plan. This term gives USSOCOM the authority to “arrange military action in time, space, and purpose to produce maximum relative combat power at a decisive place and time.”²⁴ While “synchronize” is appropriate for USSOCOM, perhaps a different term such as “orchestrate” should be added to joint lexicon for JIEDDO. Merriam-Webster defines orchestrate as “to arrange or combine so as to achieve a desired or maximum effect.” This better describes the authority JIEDDO should have to accomplish its mission.

The realignment of JIEDDO under a functional combatant command such as USJFCOM would provide this authority that JIEDDO requires and fit the model established for USJFCOM by General Pace. He states that “USJFCOM work[s] directly with the Services, combatant commands, the defense agencies, interagency and multinational partners, and the Joint Staff to develop a cohesive plan to synchronize and, when appropriate, integrate experimentation activities.”²⁵ This reorganization would provide JIEDDO the authority it requires to synchronize or orchestrate counter-IED efforts of other combatant commands as well as divest other requirements such as integrating experimentation activities to USJFCOM who has the charter to accomplish this task.

In summary, the authority granted to JIEDDO has not kept pace with the rapidly expanding budget, manpower, and associated responsibility assigned to the organization.

²³ Joint Publication 3-0, *Joint Operations*. 17 September 2006. p. GL-12.

²⁴ Joint Publication 3-0, *Joint Operations*. 17 September 2006. p. GL-30.

²⁵ GEN Peter Pace, USMC. Memorandum for Chiefs of the Services, Commanders of the Combatant Commands, Directors, Joint Staff Directorates. Subject: Joint Experimentation (JE) Guidance for FY 2006 and FY 2007. 9 January 2006.

If JIEDDO is to implement material solutions across all DoD Components, it must have the ability to compel the Services and Agencies to properly integrate those products into its existing platforms. In the same respect, JIEDDO must have a mechanism to ensure those components adequately program their budgets to sustain these capabilities. JIEDDO has a large budget, but most of that is earmarked for research and development. In addition, JIEDDO must be able to create a strategy and then force DoD Components to follow it. Without that directive authority, the DoD will continue to have multiple plans to defeat IEDs.

Recommendations

1. *Reorganize JIEDDO under a Functional Combatant Command.* Remove JIEDDO from the Office of the Secretary of Defense and place it under a functional Combatant Command such as USJFCOM. IEDs present an asymmetrical threat to the entire joint force and require a joint solution. Indeed, USJFCOM, with its mission of “Providing Joint Training and Joint Interoperable Capabilities,”²⁶ provides a logical fit for JIEDDO. As noted by Lieutenant General Wood, U.S. Army, Deputy Commander, USJFCOM, there is a “natural migration”²⁷ of JIEDDO functions to USJFCOM. As part of USJFCOM, JIEDDO could leverage USJFCOM’s COCOM authority “to organize and employ forces necessary”²⁸ to defeat IEDs. It would also retain Title 10 acquisition authority, which could be executed through the existing PPBE process. Finally, JIEDDO could leverage the planning capabilities of the COCOM staff to generate strategic guidance for all COCOMs and Services in the creation of joint solutions to defeat IEDs.
2. *Streamline the JIEDDO structure.* Eliminate functions already provided by other DoD agencies. Leverage its status as part of a COCOM organization to obtain intelligence and acquisition support from other DoD components. Condensing the JIEDDO structure

²⁶ <http://www.jfcom.mil/about/priorities.htm>

²⁷ LTG John R. Wood, USA. JFSC presentation, “The COCOM Perspective.” 1 March 2007. (With Permission).

²⁸ Joint Publication 5-0, *Joint Operation Planning*. 26 December 2006. p. GL-6.

enables it to regain its agility and ability to react quickly to changing terrorist tactics.

JIEDDO would possess the freedom to develop innovative solutions while relying on USJFCOM to execute the intelligence, planning, and training functions, which are firmly established in its structure.

3. *If not reorganized under USJFCOM, create a strategic planning staff within the JIEDDO structure.* This may require a shift of resources within JIEDDO, but should not require additional personnel. This restructuring would balance its focus between technical-solutions and strategic planning, providing a “framework to guide other DoD Components’ long-term counter-IED efforts.”²⁹ A small staff of JIEDDO planners could easily integrate IED-specific language into existing USJFCOM plans through the J-5 (Plans) staff.
4. *If not re-organized under USJFCOM, OSD should grant the Director, JIEDDO additional authority.* In order to accomplish its mission, JIEDDO must have the proper authority to compel DoD components to implement the strategic plan, sustain IED-related materiel solutions, and adopt JIEDDO training initiatives.

Conclusion

IEDs are the weapon of choice for terrorist organizations throughout the world because they provide high profile, lethal attacks that attract attention, provide propaganda, and expose vulnerabilities. Furthermore, IEDs are inexpensive and offer a means for terrorist organizations to attack superior U.S. forces not on the battlefield, but rather on the fringe; or as a weapon of mass destruction, IEDs offer a means to attack the United States directly. Lastly, this tactic fits the terrorist strategy perfectly because it is easily exported for use on a global scale. Terrorist cells throughout the world have successfully executed high profile IED attacks in every RCC

²⁹ DoD Directive 2000.19E. p. 4.

AOR—CENTCOM: USS Cole (October 2000); PACOM: Bali, Indonesia bombings (October 2002); EUCOM: London transportation system bombings (July 2005), Spanish train bombings (March 2004), and U.S. Embassy bombings in East Africa (July 1998); SOUTHCOM: Revolutionary Armed Forces of Columbia (FARC) Car bombing in Bogota, Columbia (February 2003); and the United States (pre-NORTHCOM): World Trade Center bombing (February 1993), Oklahoma City bombing (April 1995). The strategy to counter the IED threat—the primary weapon for global terrorist movements—must span AOR boundaries. As the responsibility to synchronize the global war on terror across AOR boundaries is assigned to a single combatant commander (USSOCOM), so too must the responsibility to fight the IED threat be assigned to a single organization. If that organization is to be JIEDDO, it must develop a comprehensive strategy and have the authority to guide the development of RCC plans within their assigned AOR. Furthermore, this overarching strategy must be lashed to USSOCOM's global counter-terrorism planning efforts. Plans to combat the primary terrorist weapon should mirror plans to combat the terrorists themselves.

In conclusion, JIEDDO requires fundamental changes in its approach to combating IEDs. It must redirect its efforts from a technological-based approach and apply its resources to the development of a comprehensive, strategic plan to combat IEDs. Moreover, this shift in focus requires the DoD to realign JIEDDO under a functional Combatant Command such as USJFCOM in order to complete its evolution from a 12-person Task Force to an organization with the proper structure and authority to combat the IED threat. This realignment will produce exponential gains by focusing staff efforts on strategic objectives, utilizing scarce resources more effectively, and synchronizing RCC efforts on a global scale. Success against the IED threat is critical not only to victory in Iraq and Afghanistan, but also to the global war on terrorism (GWOT). Only by adopting a new approach to combat this threat will the United States achieve

a critical pillar in the GWOT mission: “deny terrorist networks the possession or use of Weapons of Mass Destruction/Effects (WMD/E).”³⁰

³⁰ National Military Strategic Plan for the War on Terrorism. 1 February 2006. Chairman of the Joint Chiefs of Staff.

BIBLIOGRAPHY

- Barry, John, Michael Hastings and Evan Thomas. "Iraq's Real WMD." *Newsweek*. 27 March 2006 Issue
- Bender, Bryan "Panel on Iraq bombings grows to \$3b effort Critics say it has been ineffective." *The Boston Globe*, June 25, 2006.
- Chew, James S.B, Spring 1997; "Commercial Best Practices and the DoD Acquisition Process," *Acquisition Review Quarterly*. Spring 1997.
- Cohen, Wesley M. and Klepper, Steven, July 1996; "A Reprise of Size and R &D," *The Economic Journal*.
- Congressional Research Service Report for Congress, Order Code RS22330, 25 September 2006.
- DoD Directive 2000.19D, "Joint Improvised Explosive Device (IED) Defeat," 27 June 2005.
- DoD Directive 2000.19E, "Joint IED Defeat Organization," 14 February 2006.
- DoD News Release, No 1260-05, 5 December 2005, viewed 23 February 2007, <<http://www.defenselink.mil/Releases/Release.aspx?ReleaseID=9137>>
- GEN Peter Pace, USMC. Memorandum for Chiefs of the Services, Commanders of the Combatant Commands, Directors, Joint Staff Directorates. Subject: Joint Experimentation (JE) Guidance for FY 2006 and FY 2007. 9 January 2006.
- icasualties.org. <<http://icasualties.org/oif/IED.aspx>>
- Joint IED Defeat Organization. 16 November 2006. Presentation, *US Army Training Transformation Council of Colonels*, (PowerPoint Slides FOUO). Briefing posted in *Army Knowledge Online* shared folder.
- Joint Publication 3-0, *Joint Operations*. 17 September 2006.
- Joint Publication 5-0, *Joint Operation Planning*. 26 December 2006.
- McGuire, Nancy. Military Services Bring it All Together to Counter IEDs. Office of Naval Research. Viewed 23 February 2007, <www.onr.navy.mil>
- Miles, Donna, 24 January 2006, *DoD Taps Industry Know-How in Ongoing Counter-IED Efforts*, American Forces Information Services News Articles, Defense Link News, view on 3 February 2007, <www.defenselink.mil/news/Jan2006/20060124_4000.html>
- National Military Strategic Plan for the War on Terrorism. 1 February 2006. Chairman of the Joint Chiefs of Staff.

LTG James J. Lovelace Jr. and BG Joseph L. Votel, March 2004, *The Asymmetric Warfare Group: Closing the Capability Gaps*, The US Army Professional Writing Collection, viewed 22 February 2006,
http://www.army.mil/professionalwriting/writing/volume3/april2005/4_05_4.html.

LTG John R. Wood, USA. Joint Forces Staff College presentation, "The COCOM Perspective." 1 March 2007.

Senate Armed Services Committee, 14 March 2006, Statement of GEN John P. Abizaid, US Army, USCENTCOM, *Posture of the United States Central Command*.

Senate Report 109-292. Department of Defense Appropriations Bill, 2007. 25 July 2006.

Biographies

Lieutenant Colonel Richard F. Ellis, USA. LTC Ellis currently serves as the intelligence integrator at the Standing Joint Force Headquarters, USJFCOM. He recently returned from a tour in Afghanistan standing up NATO's first tactical Counter Improvised Explosive Device section and is en-route to Battalion Command upon completion of JFSC. He is married with one daughter.

Major Richard D. Rogers, USAF. Major Rogers is currently assigned to USSTRATCOM, Joint Functional Component Command for Space as the USSTRATCOM Liaison Officer to a classified organization with duty in Denver, Colorado. His specialty is space-based missile warning using a constellation of infrared sensors. He is a 1992 ROTC graduate from Valdosta State University, Valdosta, Georgia and received an MA in Administrative Management from Central Michigan University in 1997. He is married with two young children.

Lieutenant Commander Bryan Cochran, USN. LCDR Cochran is a naval special operations officer who recently completed a tour as Executive Officer of Explosive Ordnance Disposal Mobile Unit Four and is currently assigned to U.S. Special Operations Command. He is a 1993 graduate of the U.S. Naval Academy with a MS degree in Ocean Engineering. He received a MA in Management from the University of Redlands and a MA in National Security and Strategic Studies from the U.S. Naval War College. He is married with two young children and a third on the way.