

VALIDATION OF COMBINED HEAT AND POWER (CHP) MODELS TO FIELD DATA FOR A RESIDENTIAL PROTON EXCHANGE FUEL CELL (PEM) DEMONSTRATION

Franklin H. Holcomb¹, Darrell D. Massie^{2*}, John H. Kang, Daisie D. Boettner²,
and James L. Knight¹

¹ U.S. Army ERDC-CERL
Champaign, Illinois 61822

² U.S. Military Academy
West Point, New York 10996

ABSTRACT

As part of a one-year Department of Defense demonstration project, Proton Exchange Membrane (PEM) fuel cell systems have been installed at three residences to provide electrical power and waste heat for domestic hot water and space heating. The 5 kW-capacity fuel cells operate on reformed natural gas. These systems operate at preset levels providing power to the residence and to the utility grid. During grid outages, the residential power source is disconnected from the grid and the fuel cell system operates in standby mode to provide power to critical loads in the residence. One of the units was equipped with a Supervisory Control and Data Acquisition system (SCADA) that was used to collect electrical and thermal load profiles.

This paper describes the ability to model electrical and thermal loads for improved control and load management for very small systems, using limited easily obtainable forecast data.

1. INTRODUCTION

Fuel cell technology holds promise for more efficient conversion of fuel to electrical power and heat. The major challenge is to develop systems that perform as desired. Gunes and Ellis (2003) use mathematical models to evaluate energy, environmental, and economic benefits of residential fuel cell combined heat and power systems, concluding that these systems may offer a technically feasible alternative to conventional grid connected energy systems in the residential sector.

The United States Department of Defense (DoD) supports research in proton exchange membrane (PEM) fuel cells as a potential alternative power source for military applications. Military installations located throughout the United States require power and heat for fixed facilities such as offices and residences. As such, recent funding has targeted PEM fuel cells for residential application. According to Holcomb, et al. (2004), the goals of this funding program are to assess fuel cells for providing power in support of sustainable design and to study their viability as an alternative power source to the DoD; to study the effect fuel cells have on the DoD's ability to construct, operate, and maintain facilities; to assess installation and operation issues associated with the use of PEM fuel cells; and to stimulate growth in the fuel cell industry.

As part of a one-year DoD demonstration project, identical PEM fuel cell systems have been installed at three residences located on a military installation in New York to provide electrical power and waste heat for domestic hot water and space heating. The 5 kW-capacity fuel cells operate on reformed natural gas. These systems operate at preset levels providing power to the residence and to the utility grid. During grid outages, the residential power source is disconnected from the grid and the fuel cell system provides power to critical loads in the residence. Under this project, the fuel cell manufacturer is responsible for fuel cell system installation, all system operation and maintenance, and site restoration. A significant requirement of the project is that the fuel cells achieve an overall availability of at least 90% for the demonstration period.

Report Documentation Page

Form Approved
OMB No. 0704-0188

Public reporting burden for the collection of information is estimated to average 1 hour per response, including the time for reviewing instructions, searching existing data sources, gathering and maintaining the data needed, and completing and reviewing the collection of information. Send comments regarding this burden estimate or any other aspect of this collection of information, including suggestions for reducing this burden, to Washington Headquarters Services, Directorate for Information Operations and Reports, 1215 Jefferson Davis Highway, Suite 1204, Arlington VA 22202-4302. Respondents should be aware that notwithstanding any other provision of law, no person shall be subject to a penalty for failing to comply with a collection of information if it does not display a currently valid OMB control number.

1. REPORT DATE 00 DEC 2004	2. REPORT TYPE N/A	3. DATES COVERED -	
4. TITLE AND SUBTITLE Validation Of Combined Heat And Power (Chp) Models To Field Data For A Residential Proton Exchange Fuel Cell (Pem) Demonstration		5a. CONTRACT NUMBER	
		5b. GRANT NUMBER	
		5c. PROGRAM ELEMENT NUMBER	
6. AUTHOR(S)		5d. PROJECT NUMBER	
		5e. TASK NUMBER	
		5f. WORK UNIT NUMBER	
7. PERFORMING ORGANIZATION NAME(S) AND ADDRESS(ES) U.S. Army ERDC-CERL Champaign, Illinois 61822; U.S. Military Academy West Point, New York 10996		8. PERFORMING ORGANIZATION REPORT NUMBER	
9. SPONSORING/MONITORING AGENCY NAME(S) AND ADDRESS(ES)		10. SPONSOR/MONITOR'S ACRONYM(S)	
		11. SPONSOR/MONITOR'S REPORT NUMBER(S)	
12. DISTRIBUTION/AVAILABILITY STATEMENT Approved for public release, distribution unlimited			
13. SUPPLEMENTARY NOTES See also ADM001736, Proceedings for the Army Science Conference (24th) Held on 29 November - 2 December 2005 in Orlando, Florida. , The original document contains color images.			
14. ABSTRACT			
15. SUBJECT TERMS			
16. SECURITY CLASSIFICATION OF:			17. LIMITATION OF ABSTRACT
a. REPORT unclassified	b. ABSTRACT unclassified	c. THIS PAGE unclassified	UU
			18. NUMBER OF PAGES 5
			19a. NAME OF RESPONSIBLE PERSON

2. SYSTEM DESIGN

Figure 1 provides a simplified schematic of the fuel cell system. An autothermal reformer converts natural gas to hydrogen rich reformat. Deionized water provided from a storage tank is required for the reforming process. The fuel cell stack operating on air and reformat produces DC power. A cooling loop maintains the desired stack temperature by transferring energy from the stack either to the household water supply loop or to the environment via heat exchangers.

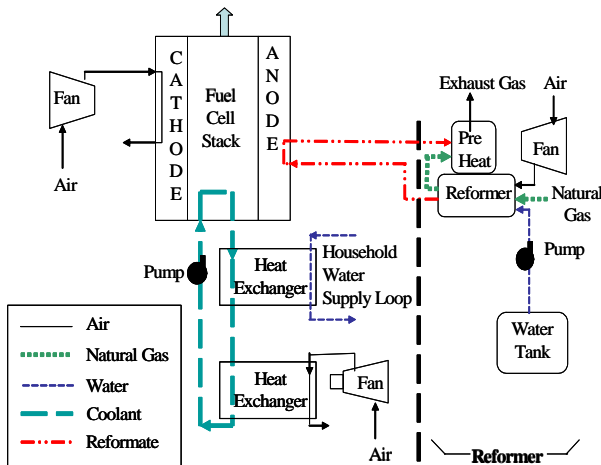

Fig. 1 Fuel cell system schematic

All three fuel cell systems are rated at 5 kW power output with user selected settings of 2.5, 4, and 5 kW. The fuel cell system's integrated battery allows the system to provide transient load following capability when the fuel cell system operates in standby mode. An inverter converts the DC supplied electricity to usable AC electricity for the residence. The fuel cells are configured to continually operate as standby power. With this configuration, power is continually supplied in parallel with grid-produced electricity. Any fuel cell system generated power that is in excess to residence demand is fed into the grid. During periods of grid outage, an automatic switch disconnects the fuel cell system from the grid and the fuel cell system provides power to the residence in response to the demand. When grid power is reestablished, the switch automatically synchronizes with the grid and then reconnects the fuel cell system.

Fuel cell heat recovery was designed for hot water flow from the fuel cell unit to the hot water heater and then to the space heater. This was done since domestic hot water normally requires a higher temperature than space heating and it simplifies control. Figure 2 provides a schematic of the design.

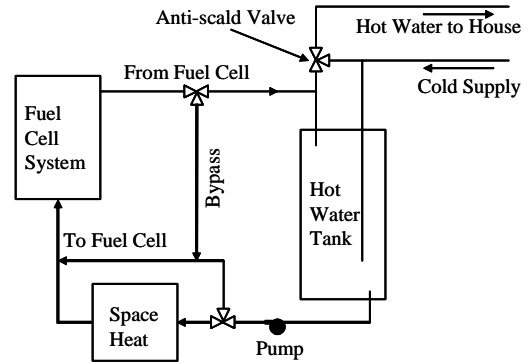

Fig. 2 Thermal heat recovery system

All three residence basements are unheated and unfinished with exposed piping in the ceiling. Space heaters (heat exchangers) were installed in all three basements and incorporated into the domestic water lines. Unfinished ceilings allowed easier installation of piping compared to the installation requirements in a finished basement. However, installation of the system as a retrofit to an existing home rather than installation as part of construction of a new home provided challenges associated with the constraints of existing structural components and lines. All new lines were run from the fuel cell unit located outside the residence through a basement window pane replaced by plywood to interior connections. Massie, et al. (2003) discuss design considerations in greater detail.

3. MODELING

The goal for developing models was to determine if artificial intelligence techniques, specifically neural networks (NN), could accurately model the thermal and electrical demand profiles. A supervisory control system might be better able to predict thermal or electrical loads in advance, to adjust setpoints for better utilize the system. This also has the potential to maximize the use of thermal or even electrical storage when the unit is grid disconnected in an electrical grid contingent condition. It might also be economically attractive to be able to predict loads when electrical buy and sell utility rates are different. Thermal storage was not available and thus not a part of the demonstration.

Hermansson (2004) performed a similar analysis, but used many more input variables to include total load (kW), outdoor temperature ($^{\circ}\text{C}$), temperature gradient ($^{\circ}\text{C}$), temperature delay ($^{\circ}\text{C}$), the time variables hour and day and heated area (m^2). Area was tested when data from more than one house were used as inputs. Temperature gradient was defined as the hourly

difference in indoor temperature to account for diurnal heat capacity and building transients. The larger number of inputs was not used for this study since they generally would not be available for load predictions.

Neural networks are a form of artificial intelligence that consists of nonlinear computer algorithms that “learn” with feedback to reproduce the existing relationship between input and output variables of complex non-linear systems (Rumelhart and McClelland 1986, Cowan and Sharp 1988, Wasserman 1989, and Bishop 1995). NN are particularly well suited for the type of problems posed by equipment modeling because they are easily configured to map several input variables to multiple output variables. Several types of NN structures are available; this study used a cascaded, feed-forward network without recursion. This type of NN has a structure similar to that of Fig. 3, where nodes (shown as circles), also known as neurons, within each layer are connected by weighting factors (shown as lines). The

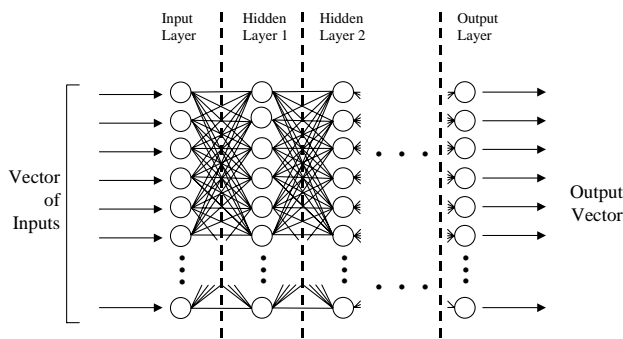

Fig. 3. Generic view of NN layered architecture.

goal of the network of layers is to map the relationship between the input vector and output vector. The nodes collect information from weighted upstream node output, process the information using an activation function, and pass the information to the next layer using more weights. Use of a nonlinear activation function, such as the sigmoid function, Massie (2001), results in nonlinear

mapping. The size of input and output vectors can vary, as can the number of nodes and layers. More nodes and weights in the network architecture allows for more complex modeling of nonlinear systems, but it is computationally intensive and may result in a network that does not obtain a generalized solution.

The development of a NN requires selection of the number of layers, the number of nodes in each layer, the activation function of each layer, and the training algorithm, which is used to minimize the error between the input and output vectors, Wasserman (1989). Once the architecture has been determined, the network is trained and then tested. In the training (or learning) phase, the NN is taught to match a known set of corresponding input and output values in order to “learn” the relationship existing between them. At the same time, the training algorithm modifies the weights associated with each neural connection. Training is the most time-consuming phase of NN development and it is critical for the success of the neural network as a predictive model. In the testing phase, also known as generalization, the NN is tested using another known set of corresponding input and output values (none of which belong to the training set) and to evaluate its performance is evaluated.

Input variables for modeling were restricted to day type, either weekday or weekend, time of day, high and low ambient temperature and recursion of the previous two recorded power or thermal loads. Recursion is a technique where the algorithm uses output from an iteration as input for a following iteration. It often improves accuracy since it provides recent predicted information to the algorithm. The limited input variables were chosen since they are readily available.

4. RESULTS

Results indicate that it is difficult to predict the electrical and thermal loads of a residence given limited input information. Figure 4 shows actual and predicted

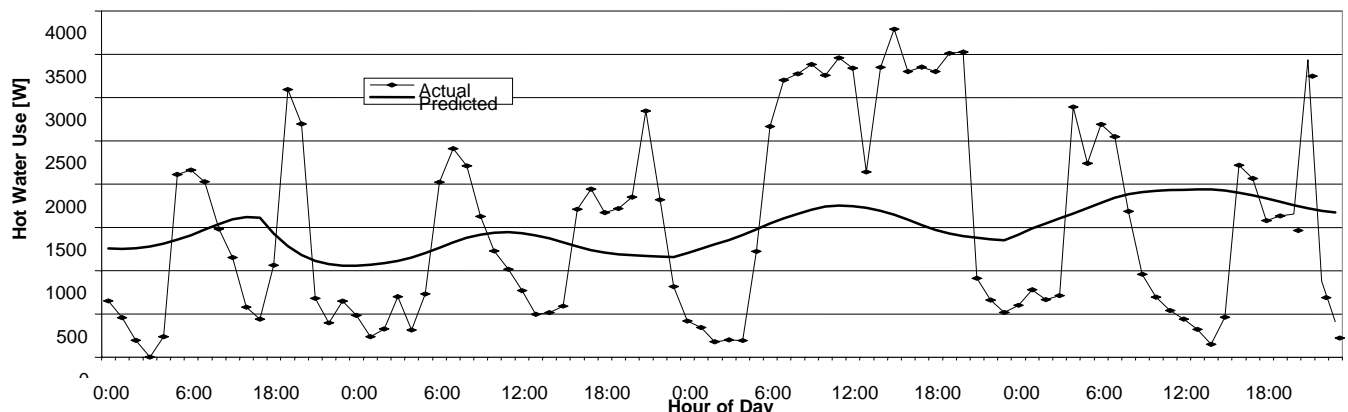

Fig 4. Actual vs. predicted domestic hot water usage

domestic hot water use over a four day period. It appears that a neural network, with the input information listed above is unable to provide detailed predictions of domestic or whole house thermal loads. The loads for an individual house are transient, sporadic and sensitive to the behavior of the occupant. Figure 5 shows the electrical demand profile for a one-day period. This too was unable to be accurately modeled in a predictive manner.

As was the case with Hermansson (2004), we found a three-fold increase in the ability to model the total thermal load (space heat plus domestic hot water). Although mathematically this looks promising, the relative constant nature of the total load profile makes this analysis uninteresting.

November 8, 2003

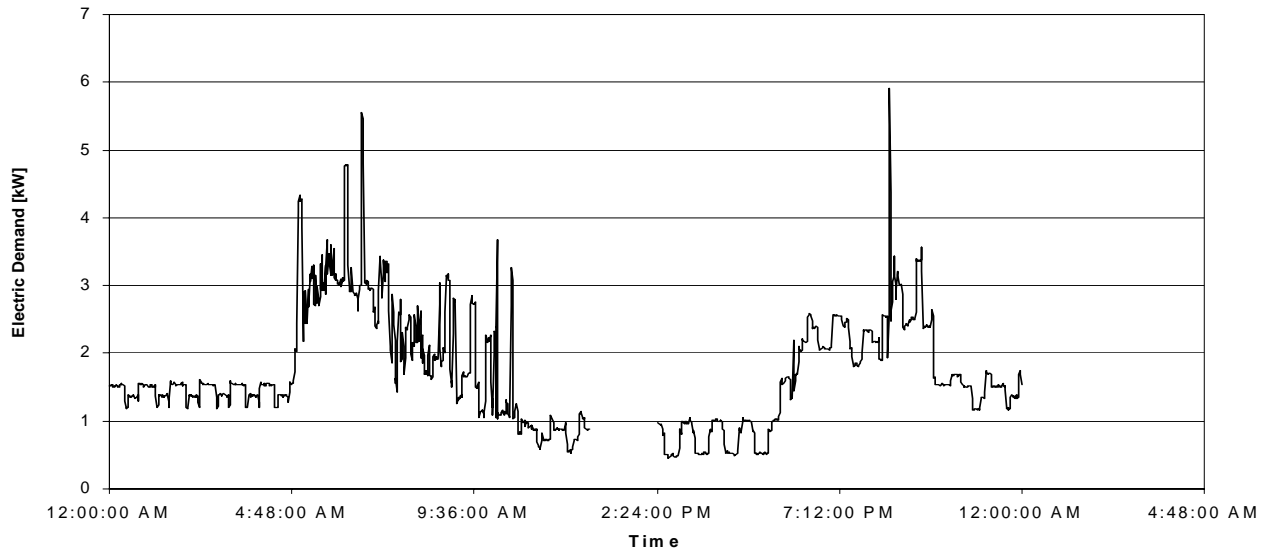

Fig 5. Electrical demand profile

5. FUTURE WORK

Similar neural network models were created for a campus electrical and thermal load profiles. Figure 6 shows the actual and predicted load profiles over a 12-day

period. Predictions varied from actual electrical demand by only 1.6 percent. Since these predictions are quite accurate, the next step might be to investigate the additional information needed for small-scale power

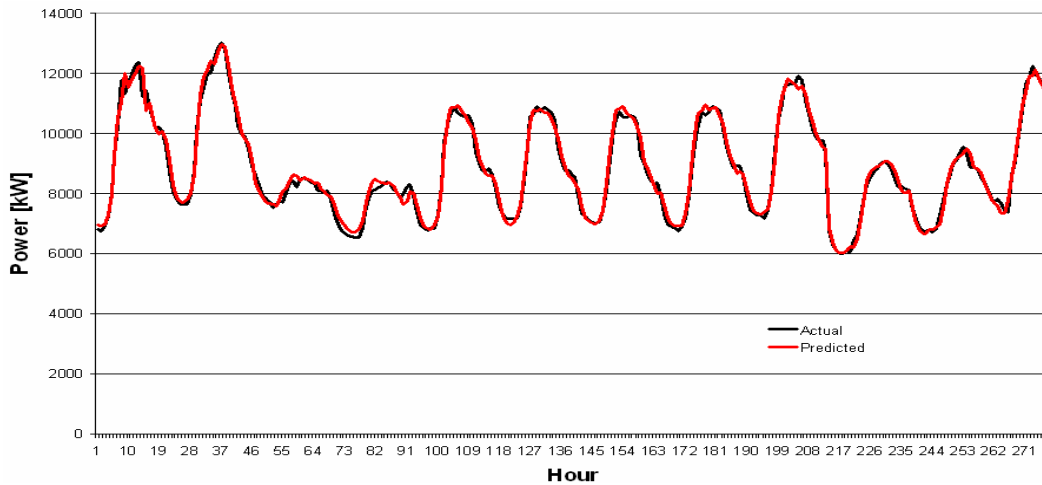

Fig 6. Campus electrical load prediction

predictions. Another corollary would be to determine if there was a threshold at which different modeling methods should be applied. Olofsson (1997) demonstrated that aggregated loads can be expected to decrease the load prediction errors by one-third

6. CONCLUSIONS

From this research it was found that very small electrical and thermal load predictions are difficult to predict with any reasonable accuracy. Loads have a tendency to swing considerably with a single household activity and unless the activity can be precisely identified, general information such as outside ambient temperature or time stamp is not sufficient to predict loads. With increased input variables, the accuracy of load predictions could be increased, but the information required to predict those future loads is generally not available.

ACKNOWLEDGMENTS

The authors would like to acknowledge the assistance and cooperation of the engineering and project management staff of Plug Power, Inc., the manufacturer of the fuel cells utilized for this demonstration project.

REFERENCES

Bishop, C.M., 1995: *Neural Networks for Pattern Recognition*. Oxford: Clarendon Press.
Cowan, J.D., Sharp, D.H., 1988. *Neural nets and artificial intelligence*, Proceedings of the American Academy of Arts and Sciences, 117, pp. 85-121.
Gunes, M. B. and Ellis, M. W., 2003: Evaluation of Energy, Environmental, and Economic Characteristics of Fuel Cell Combined Heat and Power Systems for

Residential Applications, *ASME Journal of Energy Resources Technology*, Vol. 125, pp. 208-220.

Hermansson, T., 2004: Analysis of Load Curves in One-Family Houses Using Artificial Neural Networks, School of Mechanical Engineering, Energy Economics and Planning, Department of Heat & Power Engineering, Lund Institute of Technology/Lund University, Box 118, S-221 00 Lund, Sweden

Holcomb, F. H., Davenport, D. C., Josefik, N. M., and Binder, M. J., 2004: Results of a Residential Proton Exchange Membrane (PEM) Fuel Cell Demonstration at a Military Facility in New York, *ASHRAE Transactions*, Vol. 110, Part 1.

Massie, D. D., Boettner, D. D., Massie, C. A., and Kang, J. H., 2003: Installation of Proton Exchange Membrane Fuel Cells at Residences for Combined Heat and Power, Proceedings of the Chartered Institution of Building Services Engineers/American Society of Heating, Refrigerating and Air-Conditioning Engineers, Inc. International Conference 2003, Edinburgh, Scotland, Sep 24-26.

Massie, D.D., 2001: Neural Network Fundamentals for Scientists and Engineers, ECOS 2001, International Conference on Efficiency, Cost, Optimisation, Simulation and Environmental Aspects of Energy and Process Systems, ASME, 123-128.

Olofsson, T., 1997: Building Energy Load Predictions – Based on Neural Network Techniques. Report ISBN 91-7191-358-0, Applied Physics and Electronics, Umeå University, Umeå.

Rumelhart, D.E. and McClelland, J.L., 1986: *Parallel Distributed Processing: Explorations in the Microstructure of Cognition*, MIT Press, Cambridge, MA.

Wasserman, P.D. 1989: *Neural Computing: Theory and Practice*. New York: Van Nostrand Reinhold.