

ESTCP Cost and Performance Report

(CU-0009)



Dissolved Hydrogen Analyzer

May 2006



ENVIRONMENTAL SECURITY
TECHNOLOGY CERTIFICATION PROGRAM

U.S. Department of Defense

Report Documentation Page

Form Approved
OMB No. 0704-0188

Public reporting burden for the collection of information is estimated to average 1 hour per response, including the time for reviewing instructions, searching existing data sources, gathering and maintaining the data needed, and completing and reviewing the collection of information. Send comments regarding this burden estimate or any other aspect of this collection of information, including suggestions for reducing this burden, to Washington Headquarters Services, Directorate for Information Operations and Reports, 1215 Jefferson Davis Highway, Suite 1204, Arlington VA 22202-4302. Respondents should be aware that notwithstanding any other provision of law, no person shall be subject to a penalty for failing to comply with a collection of information if it does not display a currently valid OMB control number.

1. REPORT DATE 01 MAY 2006	2. REPORT TYPE N/A	3. DATES COVERED -	
4. TITLE AND SUBTITLE Dissolved Hydrogen Analyzer: Cost & Performance Report		5a. CONTRACT NUMBER	
		5b. GRANT NUMBER	
		5c. PROGRAM ELEMENT NUMBER	
6. AUTHOR(S) Lebrón, Carmen		5d. PROJECT NUMBER CU-0009	
		5e. TASK NUMBER	
		5f. WORK UNIT NUMBER	
7. PERFORMING ORGANIZATION NAME(S) AND ADDRESS(ES) U.S. Navy/NFESC 1100 23rd Avenue Port Hueneme, CA 93043-4370		8. PERFORMING ORGANIZATION REPORT NUMBER	
9. SPONSORING/MONITORING AGENCY NAME(S) AND ADDRESS(ES) Environmental Security Technology Certification Program 901 N. Stuart Street, Suite 303 Arlington VA 22203		10. SPONSOR/MONITOR'S ACRONYM(S) ESTCP	
		11. SPONSOR/MONITOR'S REPORT NUMBER(S)	
12. DISTRIBUTION/AVAILABILITY STATEMENT Approved for public release, distribution unlimited			
13. SUPPLEMENTARY NOTES The original document contains color images.			
14. ABSTRACT			
15. SUBJECT TERMS			
16. SECURITY CLASSIFICATION OF:			17. LIMITATION OF ABSTRACT
a. REPORT unclassified	b. ABSTRACT unclassified	c. THIS PAGE unclassified	UU
			18. NUMBER OF PAGES 39
			19a. NAME OF RESPONSIBLE PERSON

COST & PERFORMANCE REPORT

ESTCP Project: CU-0009

TABLE OF CONTENTS

	Page
1.0 EXECUTIVE SUMMARY	1
1.1 BACKGROUND	1
1.2 OBJECTIVES OF THE DEMONSTRATION.....	1
1.3 REGULATORY DRIVERS	2
1.4 DEMONSTRATION RESULTS.....	2
1.5 STAKEHOLDER/END-USER ISSUES	3
2.0 TECHNOLOGY DESCRIPTION	5
2.1 TECHNOLOGY DEVELOPMENT AND APPLICATION.....	5
2.2 PROCESS DESCRIPTION	5
2.3 PREVIOUS TESTING OF THE TECHNOLOGY	8
2.4 ADVANTAGES AND LIMITATIONS OF THE TECHNOLOGY.....	8
3.0 DEMONSTRATION DESIGN	9
3.1 PERFORMANCE OBJECTIVES	9
3.2 SELECTION OF TEST SITES	9
3.3 TEST SITE DESCRIPTIONS	11
3.3.1 Site 1—SUBASE Bangor	11
3.3.2 Site 2—Fort Lewis.....	11
3.3.3 Site 3—NAS Pensacola	11
3.4 PHYSICAL SETUP AND OPERATION	11
3.5 SAMPLING/MONITORING PROCEDURES	12
3.6 ANALYTICAL PROCEDURES.....	12
4.0 PERFORMANCE ASSESSMENT	17
4.1 PERFORMANCE DATA.....	17
4.2 PERFORMANCE CRITERIA	18
4.3 DATA ASSESSMENT.....	18
4.4 TECHNOLOGY COMPARISON	21
5.0 COST ASSESSMENT.....	23
6.0 IMPLEMENTATION ISSUES	25
6.1 COST OBSERVATIONS.....	25
6.2 PERFORMANCE OBSERVATIONS.....	25
6.3 SCALE-UP	25
6.4 OTHER SIGNIFICANT OBSERVATIONS.....	25
6.5 LESSONS LEARNED.....	25

TABLE OF CONTENTS (continued)

		Page
6.6	END-USER ISSUES	26
6.7	APPROACH TO REGULATORY COMPLIANCE AND ACCEPTANCE.....	26
7.0	REFERENCES	27
APPENDIX A	POINTS OF CONTACT.....	A-1
APPENDIX B	BUBBLE-STRIP METHOD FOR ANALYZING DISSOLVED HYDROGEN	B-1

LIST OF FIGURES

		Page
Figure 1	Dissolved Hydrogen Analyzer	6
Figure 2	Dissolved Hydrogen Analyzer Implementation.....	6
Figure 3	DH Analyzer Process Flow Diagram.....	7
Figure 4	Sample Collection Points	13
Figure 5	Sample Collection Points	14
Figure 6	Sample Collection Points	15
Figure 7	Site 1 (SUBASE Bangor) DH Data	17
Figure 8	Site 2 (Fort Lewis) DH Data.....	17
Figure 9	Site 3 (NAS Pensacola) DH Results	18

LIST OF TABLES

		Page
Table 1	Performance Objectives	10
Table 2	Performance Criteria.....	19
Table 3	Expected Performance and Performance Confirmation Methods	19

ACRONYMS AND ABBREVIATIONS

AFB	Air Force Base
bgs	below ground surface
CDM	Camp Dresser & McKee, Inc.
cDCE	cis-1,2-dichloroethene
CV	coefficient of variation
DH	dissolved hydrogen
DoD	Department of Defense
EA	EA Engineering, Science, and Technology
EGDY	East Gate Disposal Yard
EPA	Environmental Protection Agency
ESTCP	Environmental Security Technology Certification Program
GLE	gas-liquid equilibration
HRC	Hydrogen Release Compound
H ₂ S	hydrogen sulfide
MGC	Anaeropack TM
mL	milliliter
mL/min	milliliters per minute
MNA	monitored natural attenuation
NAS	Naval Air Station
NATS	Natural Attenuation Test Site
NFESC	Naval Facilities Engineering Service Center
nM	nanomolar
OU8	Operable Unit 8
ppm	parts per million
PVC	polyvinyl chloride
PWIA	Public Works Industrial Area
r ²	correlation coefficient
RABITT	Reductive Anaerobic In Situ Treatment Technology
SBIR	Small Business Innovative Research

ACRONYMS AND ABBREVIATIONS (continued)

TCE	trichloroethene
TEAP	terminal electron accepting process
USGS	U.S. Geologic Survey
UST	underground storage tank
VC	vinyl chloride
VDC	volt direct current
VOC	volatile organic compounds

ACKNOWLEDGEMENTS

This report describes the demonstration of a novel analytical technology, a dissolved hydrogen (DH) analyzer and the supplemental development of the analyzer. The demonstration took place at three Department of Defense (DoD) sites.

The following individuals and organizations contributed to completion of this project:

Carmen A. Lebrón (PI)	Naval Facilities Engineering Service Center (NFESC)
Barbara Sugiyama	NFESC
Patrick J. Evans, Ph.D. (Co-PI)	CDM
Mary Trute	CDM
Roger Olsen, Ph.D.	CDM
John Eisenbeis, Ph.D.	CDM
Frank Chapelle, Ph.D.	United States Geological Survey (USGS)

The support of personnel at SUBASE Bangor, Fort Lewis, and NAS Pensacola is gratefully acknowledged.

Technical material contained in this report has been approved for public release.

1.0 EXECUTIVE SUMMARY

1.1 BACKGROUND

Monitored natural attenuation (MNA) is a cost-effective remediation approach that is applicable to many sites and embraced by the U.S. Department of Defense (DoD). MNA can be used to mitigate petroleum hydrocarbon, chlorinated hydrocarbon, and metal-contaminated sites as an alternative to groundwater pump-and-treat methods.

Determining MNA's technical applicability for a given site is based on sampling and analysis, data evaluation and modeling, and long-term monitoring. Parameters that are evaluated include concentrations of contaminants, electron acceptors, and electron donors. These concentrations in combination with hydrogeologic, soil, and microbial characteristics are used to assess the fate and transport of contaminants and the potential for natural attenuation.

Concentrations of electron acceptors or their reduced products are typically used to:

- Identify terminal electron accepting processes (TEAP) responsible for contaminant biodegradation occurring in specific areas of a contaminant plume
- Quantify assimilative capacity of an aquifer for contaminants of concern.

TEAPs affect in situ transformation of many pollutants in part by their impact on dissolved hydrogen (DH) concentrations in groundwater. Identification of TEAPs and DH concentrations can indicate specific degradation patterns of contaminants such as chlorinated hydrocarbons and benzene.

Although DH measurements are proven to be a useful tool to delineate the TEAPs in aquifers, this parameter is not measured in the field because of the expensive analytical equipment required. Camp Dresser & McKee, Inc. (CDM) invented and developed a portable DH analyzer. Such an analyzer does not exist elsewhere. The only other means available to measure DH in the field at the required low concentrations involves use of the "bubble-strip" method in conjunction with a reduction gas analyzer (Chapelle et al, 1997). This method is difficult to perform, time-consuming, and expensive; therefore, it has not gained widespread acceptance as a field analytical method.

1.2 OBJECTIVES OF THE DEMONSTRATION

The main objectives of this demonstration were to:

- Validate the DH analyzer by determining the correlation between the DH analyzer results and those obtained using the standard bubble-strip/reduction gas analyzer method.
- Quantify operational costs associated with using the DH analyzer.

Performance of the DH analyzer was evaluated based on the following criteria:

- Accuracy as demonstrated by a one-to-one correlation between the standard bubble-strip method and the novel analyzer
- Range as demonstrated by a response from less than 0.2 nanomolar (nM) to greater than 10 nM DH
- Precision as demonstrated by a low coefficient of variation among replicate analyses
- Sample throughput as demonstrated by low analysis time relative to the bubble-strip method
- Mechanical reliability as demonstrated by a low incidence of failure
- Versatility as demonstrated by acceptable performance at all three sites.

1.3 REGULATORY DRIVERS

Dissolved hydrogen is referenced in the Environmental Protection Agency (EPA) technical guidance on natural attenuation of chlorinated solvents (EPA, 1998); however, analysis of this analyte is not required at this time and is considered optional by regulatory agencies. Additionally, no method for DH measurement has been approved by any regulatory agency.

1.4 DEMONSTRATION RESULTS

At each of the three demonstration sites, DH measurements were taken from 10 monitoring wells using the DH analyzer and the reference (bubble-strip) method. The correlation coefficients for the two methods for Sites 1, 2, and 3 were 0.80, 0.24, and 0.01, respectively. The variability of correlation of the DH analyzer results to bubble-strip method results has been determined to be most likely due to interferences from dissolved gases, primarily methane and hydrogen sulfide (H₂S), in the groundwater analyzed. Specifically, the ability of the various hydrogen sensors tested to accurately measure gaseous hydrogen was negatively impacted by the presence of other gases that partitioned from groundwater during gas-liquid equilibration (GLE).

The interference of other dissolved gases impacted how the DH analyzer performed against several performance criteria, including accuracy, precision, sensitivity, and range. It was evident that further investigation and testing of hydrogen sensors not susceptible to interference by other dissolved gases would be required for the DH analyzer to be a reliable field instrument. Additionally, the viability, or lack thereof, of the DH analyzer could not be demonstrated at this time because of poor precision (e.g., coefficient of variation of 17% to 67%) of the standard reference method (i.e., the bubble-strip method). Therefore, ESTCP discontinued further demonstration of the analyzer.

1.5 STAKEHOLDER/END-USER ISSUES

These demonstrations showed that while the DH analyzer is not yet ready for commercialization, with further development it can be a valuable tool for providing accurate field analyses of dissolved hydrogen. This further development needs to focus on developing better sensors, adding better adsorbents for interfering gas removal, developing leak detection systems, and improving mechanical stability.

This page left blank intentionally.

2.0 TECHNOLOGY DESCRIPTION

2.1 TECHNOLOGY DEVELOPMENT AND APPLICATION

The DH analyzer was largely developed under a Phase II Small Business Innovative Research (SBIR) grant funded by the Air Force and was documented in 1999 (AGI, 1999). The intended use is site characterization and monitoring in MNA applications and enhanced bioremediation projects. During site characterization, DH measurements can indicate the dominant TEAPs in different areas of a given site. Knowledge of these TEAPs allows scientists, engineers, and regulators to make predictions as to the potential fate of various contaminants of concern. For example, a DH of 0.2 to 0.8 nM can indicate that iron reduction is dominant. This TEAP may suggest that reduction of cis-1,2-dichloroethene (cDCE) to vinyl chloride (VC) or ethene is unlikely to be significant. It may also suggest that oxidative mineralization of cDCE or VC to carbon dioxide may occur. Understanding the potential for these different pathways is one of the first steps to documenting natural attenuation at a site. The DH analyzer can also be used to monitor the progress of a natural attenuation remedy. If reductive dechlorination of trichloroethene (TCE) to ethene is the basis of natural attenuation at a given site, it is likely predicated on maintenance of a methanogenic TEAP. Verification that DH is being maintained within the methanogenic TEAP range (5 to 20 nM) is possible only if DH measurement is practical. In addition to MNA, DH measurement can be used to monitor and assess performance of enhanced anaerobic bioremediation remedies. These remedies include injection of electron donors such as molasses, volatile fatty acids (e.g., via reductive anaerobic biological in situ treatment technology [RABITT]), lactic acid, or commercial products such as Regenesi's Hydrogen Release Compound (HRC[®]). This technology is used to increase DH concentrations and in turn promote reductive dechlorination of chlorinated organics such as TCE. DH measurement can be used to determine if these increased DH concentrations are attained and whether sufficient electron donor is injected.

2.2 PROCESS DESCRIPTION

The DH analyzer is a field-ready instrument enclosed in a protective case (Figures 1 and 2) that operates off a 12-volt DC current power supply and is connected to the discharge of a groundwater extraction pump such as a bladder pump. Figure 3 is a schematic of the DH analyzer. Groundwater is pumped into the analyzer and passes through a GLE device that transfers dissolved hydrogen from groundwater to a carrier gas. The carrier gas is then treated by a series of catalysts to remove interfering gases. The hydrogen in the treated carrier gas is then measured using a highly sensitive solid-state sensor. The analyzer is controlled by a microprocessor, and initial data indicated that a linear response sensitive to less than 0.2 nM can be attained. Further information on the technology theory can be found in the references (Evans, 2001a, b, and c).

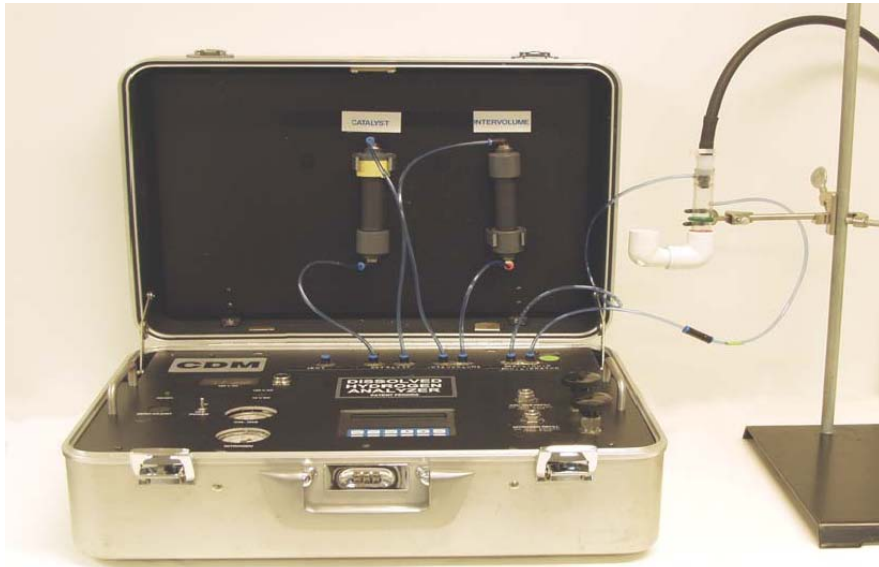

Figure 1. Dissolved Hydrogen Analyzer.



Figure 2. Dissolved Hydrogen Analyzer Implementation.

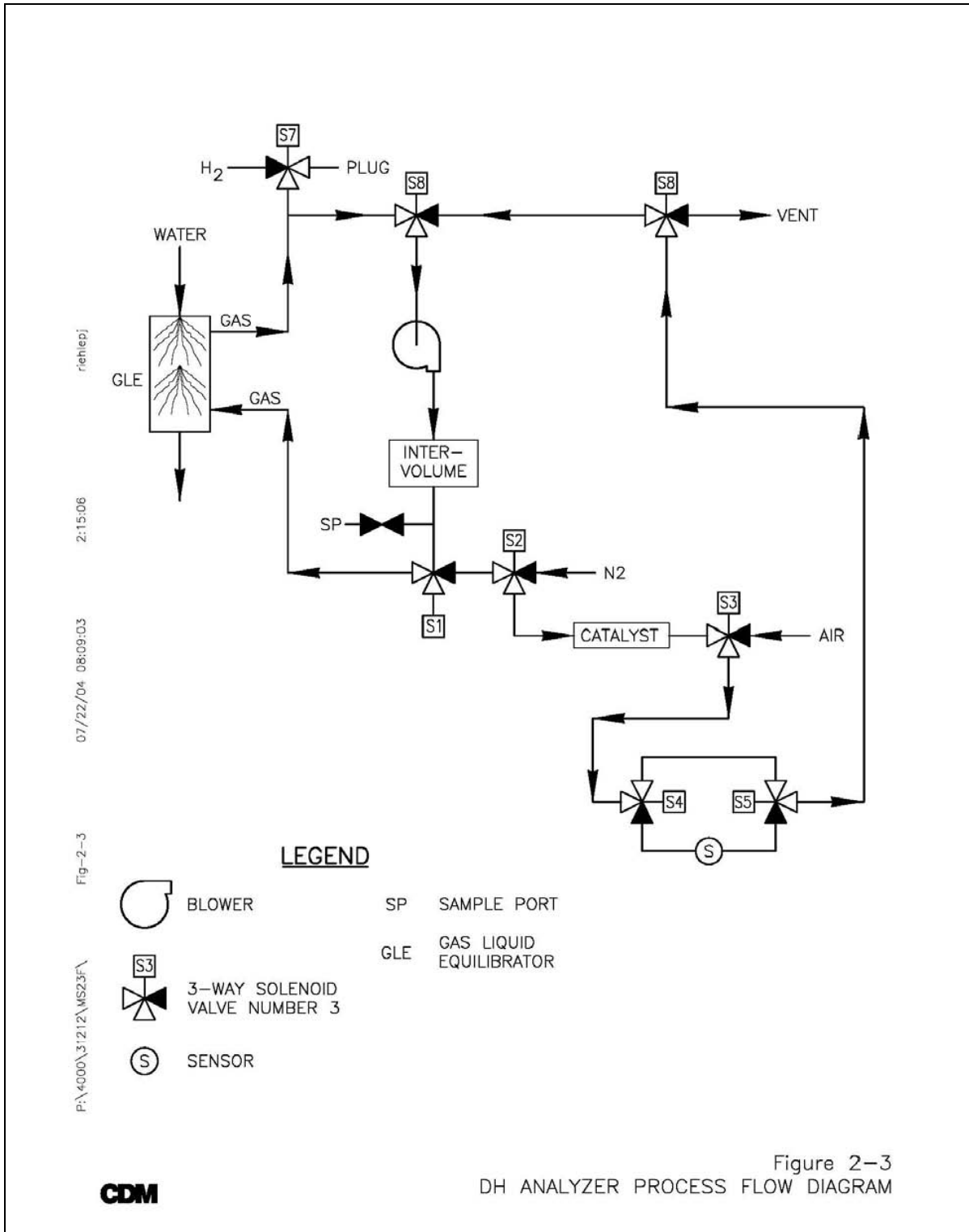

Figure 3. DH Analyzer Process Flow Diagram.

2.3 PREVIOUS TESTING OF THE TECHNOLOGY

Earlier prototypes of the DH analyzer were field tested at the following eight sites across the United States during 1998 (AGI, 1999):

- Natural Attenuation Test Site (NATS) in Columbus, Mississippi.
- Chlorinated solvent site (USG) in Baltimore, Maryland.
- Chlorinated solvent site (Unisys) in Plymouth, Michigan.
- Operating gasoline station (Chevron) in Nisqually, Washington.
- Chlorinated solvent site at (Union Pacific) rail yard in Sacramento, California.
- Petroleum hydrocarbon site at Hill Air Force Base (AFB) in Ogden, Utah.
- Chlorinated solvent site at (Union Pacific) rail yard adjoining Hill AFB.
- Petroleum hydrocarbon site in Laurel Bay, South Carolina.

Additional testing was conducted during this project and is described in the Environmental Security Technology Certification Program (ESTCP) Final Report (NFESC and CDM, 2004).

2.4 ADVANTAGES AND LIMITATIONS OF THE TECHNOLOGY

Available methods to quantify DH in groundwater involve either (1) stripping the hydrogen from the groundwater into a carrier gas that is then analyzed at an off-site laboratory with standard turnaround time issues or (2) using the bubble-strip method described briefly in Section 1.1 and in detail in Appendix A. This existing method is difficult, time consuming, and expensive to use; therefore, it has not gained widespread acceptance as an analytical method. The DH analyzer was shown during Phase II work under an SBIR grant to give comparable results to the standard bubble-strip/reduction gas analyzer method; however, the DH analyzer is simpler to use and, unlike the off-site lab method, produces near real-time results. Also, the DH analyzer costs are significantly less than the standard bubble-strip method.

The DH analyzer is field-portable and incorporates the GLE and hydrogen sensing into a single instrument eliminating the difficulty associated with the bubble-strip method. The instrument is user-friendly and requires little technical knowledge for operation. As with any electromechanical device, the DH analyzer requires periodic maintenance, including replacing filters, catalysts, and gases.

Based on the results of this demonstration, it is clear that a major limitation of the analyzer as it now exists is the need for a hydrogen sensor that minimizes interferences from other dissolved gases and has sensitivity to hydrogen to produce detection limits near 0.2 nM. Further investigation is needed to identify such a sensor. A relatively minor limitation of the instrument is the analysis time required, which is expected to be about 30 minutes but may be up to 1 hour. This time may seem excessive, but, it is comparable to the bubble-strip method and provides near real-time results (as opposed to the off-site lab method). An indirect limitation pertains to well materials of construction, direct push technologies, and use of electric submersible pumps, all of which can result in hydrogen generation, thus giving falsely elevated DH concentrations. Although this limitation is not directly associated with the DH analyzer, it can result in misleading data if not addressed.

3.0 DEMONSTRATION DESIGN

The demonstration described in this section was performed by CDM in cooperation with the NFESC as the principal investigator. Points of contact involved in the demonstration are listed in Appendix A. The demonstration was conducted in accordance with the Technology Demonstration Plan (NFESC and CDM, 2001). The Technology Demonstration Plan also described the demonstration of a second MNA tool – a bioavailable ferric iron assay – and the demonstration of this tool is described in a separate report.

3.1 PERFORMANCE OBJECTIVES

Performance of the DH analyzer was compared to the bubble-strip method used in conjunction with the reduction gas analyzer. At Naval Air Station (NAS) Pensacola, Dr. Frank Chapelle of the U.S. Geological Survey (USGS) coordinated validation of the DH analyzer and ensured that the bubble-strip/reduction gas analyzer technique was correctly executed. Performance was evaluated based on the following objectives identified in the Demonstration Plan and also shown in Table 1:

- **Accuracy**, as demonstrated by a one-to-one correlation between the two analytical techniques
- **Range**, as demonstrated by a response from less than 0.2 nM to greater than 10 nM
- **Precision**, as demonstrated by a low coefficient of variation among replicate analyses
- **Sample throughput**, as demonstrated by low analysis time relative to the bubble-strip method
- **Mechanical reliability**, as demonstrated by a low incidence of failure
- **Versatility**, as demonstrated by acceptable performance at all three sites.

3.2 SELECTION OF TEST SITES

Technical and administrative data associated with contaminated areas at each of the sites identified in the Technology Demonstration Plan were acquired and reviewed. Specific information included:

- Availability of an existing groundwater monitoring well network
- Geological and hydrogeological characteristics
- Terminal electron-accepting processes occurring in the aquifer
- Concentrations of parent compounds and presence of daughter products
- Groundwater chemistry

- Ability to drill on site
- Availability and quality of existing site characterization documentation

Table 1. Performance Objectives.

Type of Performance Objective	Primary Performance Criteria	Expected Performance (Metric)	Actual Performance Objective Met?
Qualitative	1. Sample processing rate	Equal to or better than bubble-strip method	Not determined ¹
	2. Mechanical reliability	Low breakdown incidence	No
	3. Versatility	Applicability to all sites	No
	4. Ease of use	Typical operator training and labor required	Yes
Quantitative	1. Accuracy	Percent error < 10 percent; correlation coefficient (r ²) > 0.9	No
	2. Precision	Coefficient of variation (CV) for DH analyzer equal to or less than CV for reference method	Yes
	3. Sensitivity	< 0.2 nM	Yes (if no interference)
	4. Range	> 10 nM	Yes (if no interference)

¹Will depend on the hydrogen sensor ultimately used.

The objective was to select sites that offered a range of DH concentrations, geochemical characteristics, and TEAPs. This range of DH concentrations enabled validation of the DH analyzer over its full range.

The five sites originally selected for field testing in the Demonstration Plan, include:

- Petroleum hydrocarbons at Laurel Bay Exchange Marine Corps Air Station in Beaufort, South Carolina (Laurel Bay)
- Dissolved petroleum hydrocarbons and chlorinated volatile organic compounds (VOC) at Bangor Naval Submarine Base in Kitsap County, Washington (SUBASE Bangor)
- Chlorinated VOCs at Fort Lewis Logistics Center near Tillicum, Washington (Fort Lewis)
- Chlorinated VOCs at Dover AFB in Dover, Delaware (Dover AFB)
- Chlorobenzene plume at NAS Pensacola (Pensacola)

Ultimately, an analyzer was demonstrated at three sites. The DH analyzer was demonstrated at SUBASE Bangor, Fort Lewis, and then at NAS Pensacola.

3.3 TEST SITE DESCRIPTIONS

3.3.1 Site 1—SUBASE Bangor

The study area is Operable Unit 8 (OU8), located in the Public Works Industrial Area (PWIA) of Bangor, which is located near the town of Silverdale, Washington. An on-site underground storage tank (UST) is believed to be the source of unleaded gasoline released into the surrounding media between 1982 and 1986. In 1986, soil vapor extraction/air system and product recovery were implemented to clean up the site. To date, liquid petroleum hydrocarbons remain in several monitoring wells at the PWIA, and chlorinated VOCs are present in site groundwater (EA, 2000).

3.3.2 Site 2—Fort Lewis

Fort Lewis Logistics Center is located south of Tacoma, Washington. The source area is the East Gate Disposal Yard (EGDY), situated at the northwest corner of the base. Originally, the site was used for storage and disposal of various solid and liquid waste products of the Fort Lewis Logistics Center. Since 1982, studies have been conducted at the EGDY to verify and delineate contamination at the site. Affected media were soil and groundwater, with the prominent contaminant being TCE (Battelle, 2000). Battelle Memorial Institute (in cooperation with the Air Force Research Laboratory, USGS, EPA, and Cornell University) is performing RABITT at the East Gate Disposal Yard at Fort Lewis (Battelle, 2000).

3.3.3 Site 3—NAS Pensacola

This site is situated near Pensacola Bay in the far northwest corner of Florida (USGS, 1999). The area consists predominantly of marine and fluvial terrace deposits ranging from fine- to medium-grained sands, silts, clays, and gravel. The site has a shallow aquifer and a deeper confined aquifer (referred to as the underlying main producing zone). There is a 20-foot-thick confining barrier of low-permeable silts and clays that separate the upper and lower aquifers. The upper aquifer is composed of fine- to medium-grained sands. The main producing zone is used locally as a water supply and consists of permeable sands and gravel. Two plumes have been identified at the site, one consisting of chlorinated ethenes and the other chlorinated benzenes. Most contaminants on site are in the upper aquifer region, and the depth of contamination ranges from 20 to 40 feet below ground surface (bgs).

3.4 PHYSICAL SETUP AND OPERATION

Startup responsibilities included well sampling and operation of the DH analyzer. Site-specific security procedures were determined and followed at all sites. Two people from CDM were on site during each demonstration. Dr. Frank Chapelle of the USGS was at Site 3 for completion of confirmatory analyses.

Upon arrival at each site, the DH analyzer was inspected to determine if damage had occurred during shipment. A calibration run was then performed to ensure proper operation. Compressed nitrogen required for the reduction gas analyzer was obtained from a local gas supply vendor. The DH analyzer and groundwater sampling pump operated off 12 volt direct current (VDC)

using a cigarette lighter adapter in the vehicle being used on site. The reduction gas analyzer required 120 volts AC.

3.5 SAMPLING/MONITORING PROCEDURES

Figures 4 through 6 show maps and monitoring well locations for each of the three demonstration sites.

To evaluate the performance objectives listed in Table 4, the three site demonstrations followed the experimental design described in the Demonstration Plan. Well sampling for DH analysis began by measuring the water level in the subject monitoring well using an electronic sounder. Then, tubing connected to either a bladder or peristaltic pump was lowered into the subject monitoring well. In wells that already contained sampling tubes, the intake to the sampling pump was connected to the sampling tube. The sampling pump was typically operated at a flow rate between 200 and 1,000 mL/min and discharged into a 5-gallon bucket. Field parameters (i.e., pH, temperature, dissolved oxygen, Eh, and specific conductivity) were monitored using a Hydrolab™. When these parameters were stable, the bubble-strip/reduction gas detection method was used to measure the DH concentration. The DH analyzer was connected to the discharge of a second sampling pump and operated in parallel with the bubble-strip method.

At each of the three demonstration sites, approximately 10 monitoring wells were measured for DH. Wells were selected based on an evaluation of site conditions to provide a wide range of anticipated DH concentrations. Measurements using the bubble-strip/reduction gas detection method and the DH analyzer were repeated up to four times at several wells.

3.6 ANALYTICAL PROCEDURES

The DH analyzer was used to measure DH in groundwater samples at each of the sites. The results of the DH analyzer were compared against the standard bubble-strip method. The bubble-strip method with reduction gas analyzer detection is considered to be the standard method for DH analysis and was used to verify the DH analyzer results. Validation of the DH analyzer depends on comparable results to the bubble-strip method DH measurements. CDM was responsible for operating the DH analyzer. CDM performed the bubble-strip method at SUBASE Bangor and Fort Lewis. Dr. Frank Chapelle of the USGS assisted in performing the bubble-strip method and evaluating DH results at Pensacola NAS.

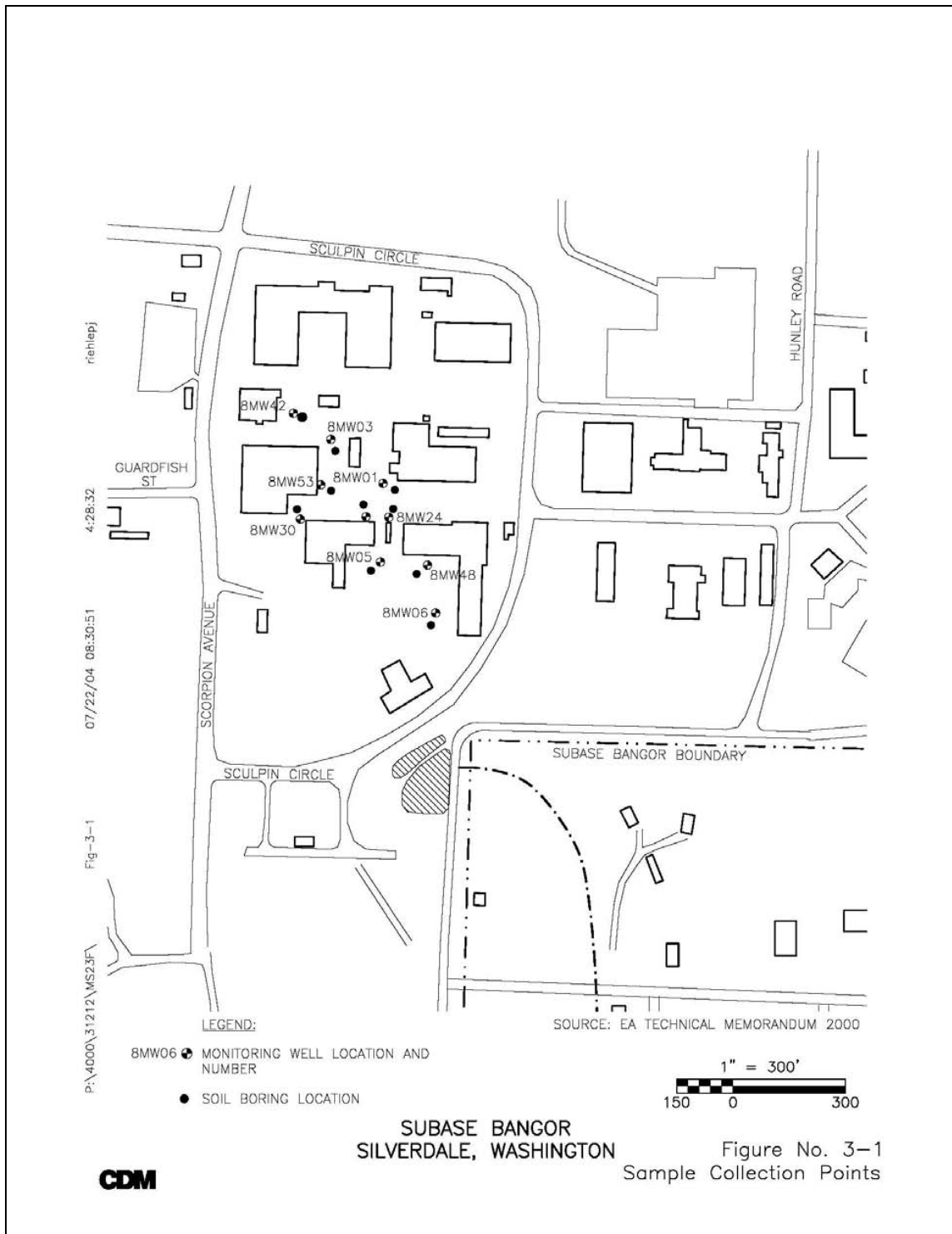

Figure 4. Sample Collection Points.

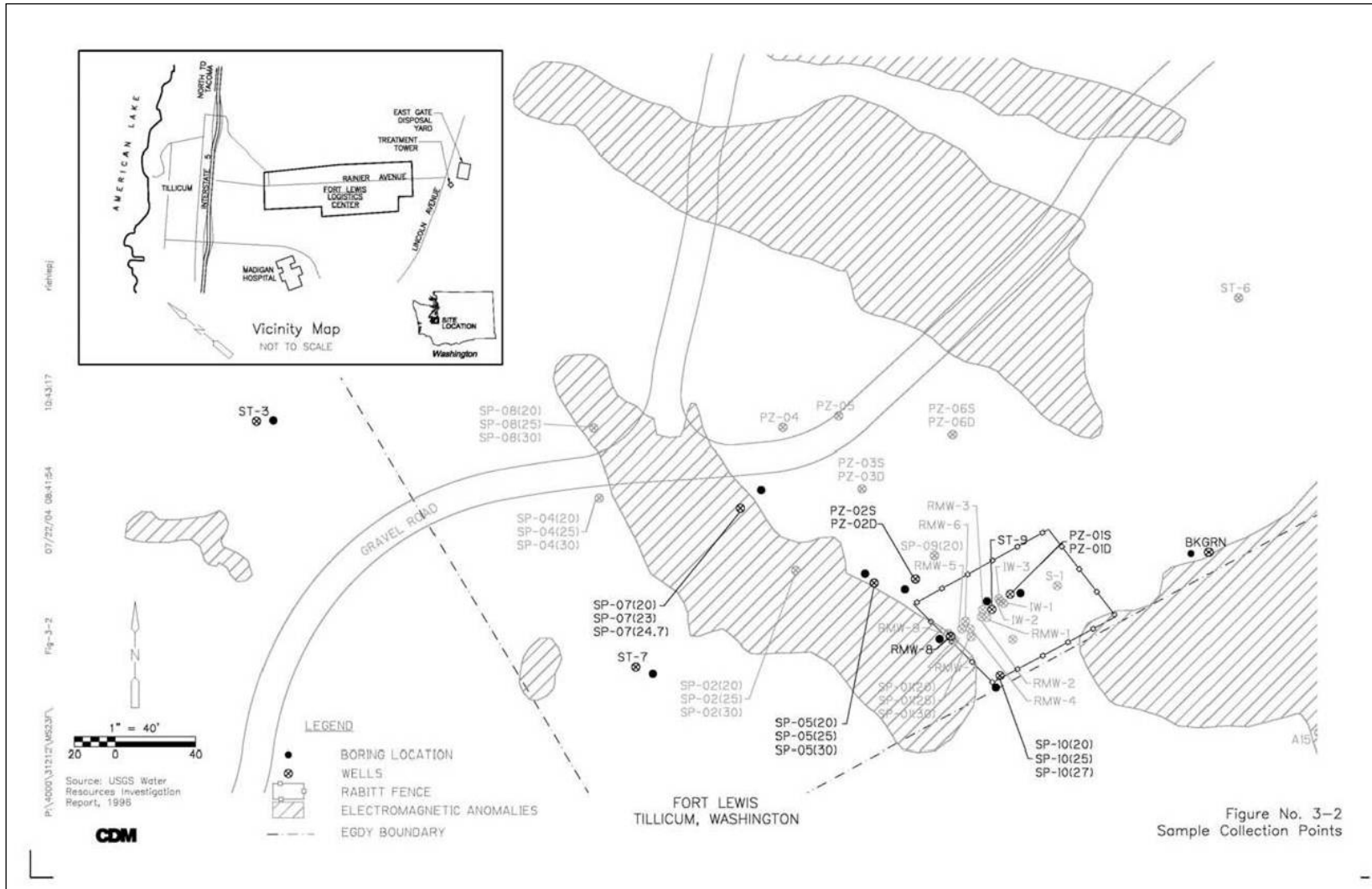

Figure 5. Sample Collection Points.

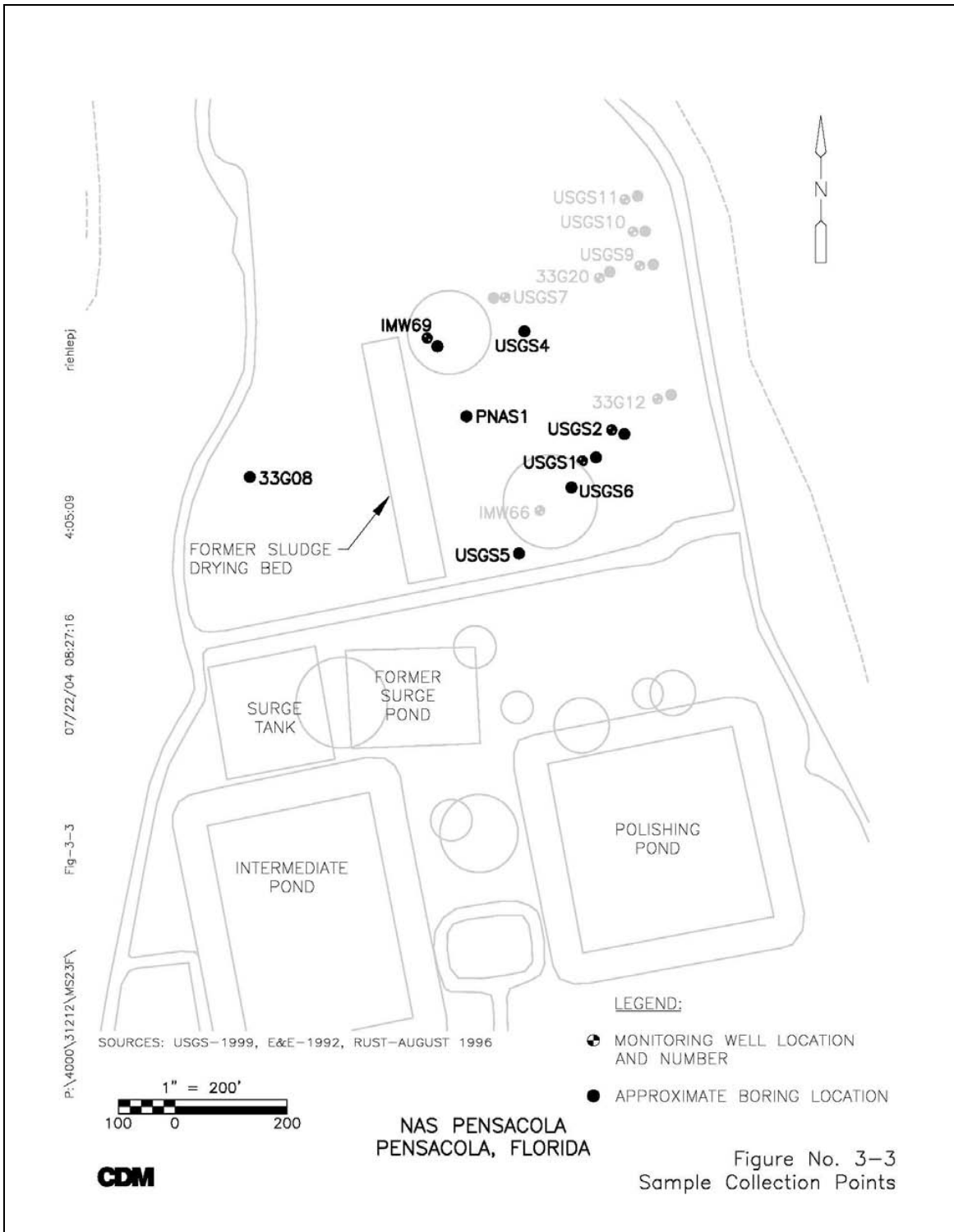

Figure 6. Sample Collection Points.

This page left blank intentionally.

4.0 PERFORMANCE ASSESSMENT

4.1 PERFORMANCE DATA

Results of the DH analyzer and the bubble-strip method are summarized in Figures 7, 8, and 9, for Sites 1, 2, and 3, respectively. In general, the precision of the DH analyzer was similar to that of the bubble-strip reference method. The accuracy of the DH analyzer was poor compared to the bubble-strip reference method. Further discussion of the results is presented in Section 4.3.

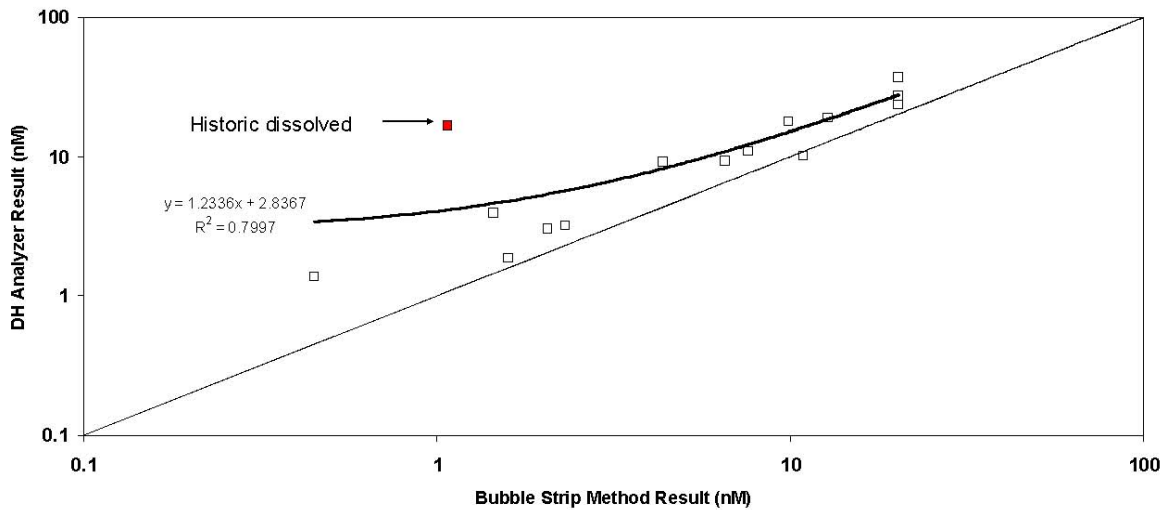

Figure 7. Site 1 (SUBASE Bangor) DH Data.

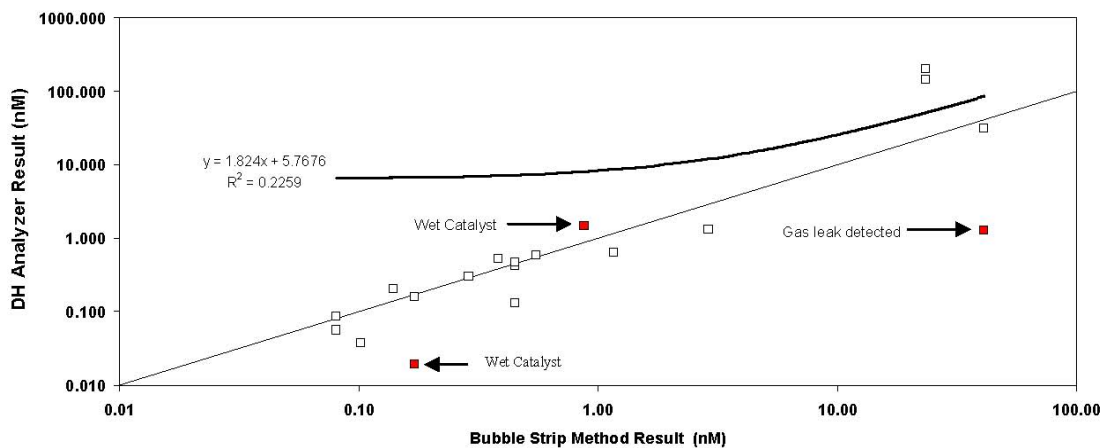

Figure 8. Site 2 (Fort Lewis) DH Data.

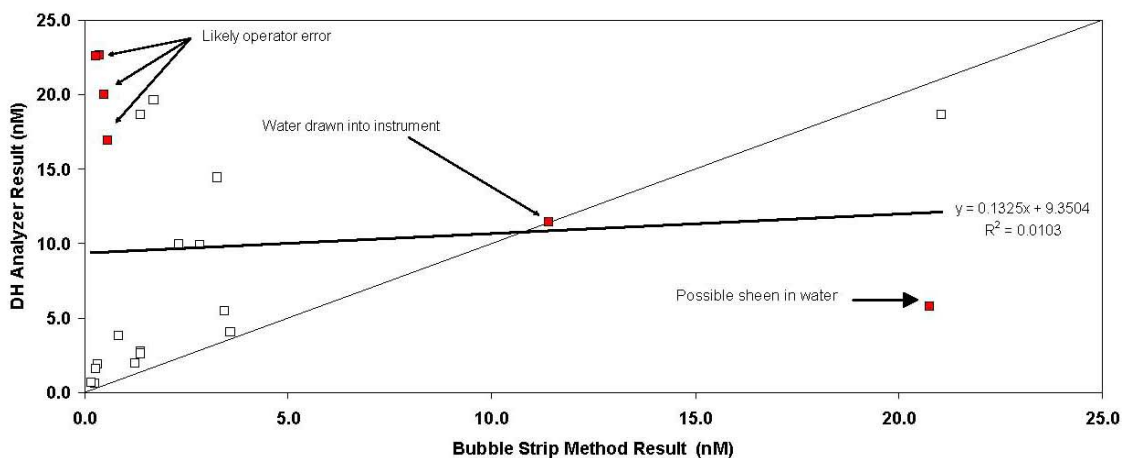

Figure 9. Site 3 (NAS Pensacola) DH Results.

4.2 PERFORMANCE CRITERIA

Performance criteria used to evaluate the performance of the DH analyzer are given in Table 2 and are categorized as primary criteria (the project’s performance objectives) or secondary criteria.

The primary method of evaluating the DH analyzer’s performance was to determine the correlation between the analyzer results and bubble-strip method results for samples that were colocated in the same well. However, other methods, metrics, and criteria were used to evaluate performance of the analyzer. Table 3 presents a summary of these and lists them as either primary criteria (performance objectives) or secondary criteria. Within these two categories, the criteria are further divided as being qualitative or quantitative.

4.3 DATA ASSESSMENT

The correlation coefficients for the two methods for Sites 1, 2, and 3 were 0.80, 0.24, and 0.01, respectively. The variability of correlation of the DH analyzer results to bubble-strip method results was most likely due to interferences from dissolved gases (primarily methane and H₂S) in the groundwater analyzed. Specifically, the ability of the various hydrogen sensors tested to accurately measure gaseous hydrogen was negatively impacted by the presence of other gases that partitioned from groundwater in the GLE device. For example, Figure 7 indicates a data point for a well that had historic dissolved methane. Because the sensor is sensitive to methane, the high DHA result is likely attributable to this interference. Much but not all of the poor correlation in Figure 9 was attributed to operator error or high sulfide concentrations in groundwater. A direct correlation between error and sulfide concentration was not evident. Sulfide did not completely explain the poor correlation, and other possible interferences or sensor instabilities are likely to exist.

Table 2. Performance Criteria.

Performance Criteria	Description	Primary or Secondary
Sample throughput	Low analysis time relative to bubble strip method	Primary
Mechanical reliability	Low incidence of mechanical failure	Primary
Versatility	Acceptable performance at all three demonstration sites	Primary
Ease of use	Minimal user training required	Primary
Accuracy	Correlation between DH analyzer results and bubble-strip method results	Primary
Precision	Low coefficient of variation among replicate analyses	Primary
Sensitivity	Detection limit for DH <0.2 nM	Primary
Range	Accurate results between <0.2 and 10 nM DH	Primary
Hazardous materials	Little or no hazardous material generated during use of analyzer	Secondary
Process waste	Little or no process waste generator during analyzer use	Secondary
Factors affecting technology performance	Few interferences and accurate operation possible over a wide range of groundwater quality and field conditions	Secondary
Maintenance	Easily kept in operating order with infrequent part replacement	Secondary
Scale-up constraints	Ease in producing analyzer commercially	Secondary

Table 3. Expected Performance and Performance Confirmation Methods.

Performance Criteria	Expected Performance Metric (Predemonstration)	Performance Confirmation Method	Actual (Postdemonstration)
PRIMARY PERFORMANCE CRITERIA (Qualitative)			
Sample throughput	Equal to or better than bubble-strip method	Experience from demonstration operation	Analysis time similar to bubble-strip method (~1 hour)
Mechanical reliability	Low breakdown incidence	Experience from demonstration operation	Further development needed to improve mechanical reliability
Versatility	Applicability to all demonstration sites	Comparison of results from different sites and laboratory testing	Further development needed for the hydrogen sensor to improve versatility through reduction in interfering dissolved gases
Ease of use	Operator training and labor required similar to other field equipment	Comparison to operator requirements for other commonly used field instruments	Ease of operation similar to other field instruments, although calibration could be simplified
PRIMARY PERFORMANCE CRITERIA (Performance Objectives) (Qualitative)			
Accuracy	Percent error <10% $r^2 >0.9$	Correlation with bubble-strip/reduction gas analyzer reference method	Accuracy was highly dependent on types and amounts of interfering gases. Site 1 $r^2 >0.24$; Site 3 $r^2 = 0.01$

Table 3. Performance Criteria (continued).

Performance Criteria	Expected Performance Metric (Predemonstration)	Performance Confirmation Method	Actual (Postdemonstration)
Precision	CV for DH analyzer equal to or less than CV for reference method	CV between replicates taking into account best CV attained with the bubble-strip/reduction gas analyzer reference method.	Average CVs: Site 1 – 34% for DH analyzer and 67% for reference method Site 2 – 64% for DH analyzer and 34% for reference method Site 3 – 20% for DH analyzer and 17% for reference method Overall, CVs similar to reference method
Sensitivity	Detection limit for DH <0.2 nM	Detection of DH concentrations less than 0.2 nM as determined by bubble-strip/reduction gas analyzer reference method.	Detection limit for DH <0.2 nM when no interferences presence
Range	> 10 nM	Ability to quantify DH concentrations greater than 10 nM as determined by bubble-strip/reduction gas analyzer reference method.	> 10 nM when no interferences present
SECONDARY PERFORMANCE CRITERIA (Qualitative)			
Hazardous materials	No hazardous materials produced	Evaluation of materials needed for operation	No hazardous materials produced
Process waste	No process waste produced	Observation	No process waste produced. Very small amounts of spent MGC, Carulite, molesieve are produced.
Factors affecting performance • Throughput • Groundwater quality	<ul style="list-style-type: none"> • Analysis time ≤ 1 hr • No interferences under typical groundwater conditions 	<ul style="list-style-type: none"> • Time/sample analysis • Performance not affected by groundwater quality 	<ul style="list-style-type: none"> • Analysis time ≤ 1 hr • Other dissolved gases interfered with DH analysis
Maintenance	Maintenance requirements similar to other field instruments (gas and filter replacement)	Comparison of field records to operator requirements for other commonly used field instruments	Gas and filter replacement are primary maintenance requirements (i.e., not dissimilar to other field instruments)
Scale-up constraints	No commercialization constraints	Investigate ability to easily produce commercially	No commercialization constraints likely except relatively small market, but depends on further development results and hydrogen sensor used

The interference of other dissolved gases impacted how the DH analyzer performed against several performance criteria, including accuracy, precision, sensitivity, and range. It is evident that further investigation into and testing of hydrogen sensors is required for the DH analyzer to be a reliable field instrument. Additionally, the viability, or lack thereof, of the DH analyzer could not be demonstrated at this time because of poor precision (e.g., coefficient of variation of 17 to 67%) of the standard reference method (i.e., the bubble-strip method). Since further development of the DH analyzer was beyond the scope of the ESTCP demonstration, evaluation of the current configuration of the DH analyzer was discontinued after Site 3 (NAS Pensacola).

4.4 TECHNOLOGY COMPARISON

No other field portable method is available for measuring dissolved hydrogen in groundwater. Equilibrated gas samples can be collected and sent to a fixed laboratory if desired.

This page left blank intentionally.

5.0 COST ASSESSMENT

Given the developmental requirements of the DH analyzer before it can be commercialized and at ESTCP's direction (e-mail from Dr. Andrea Leeson to Carmen A. Lebrón dated December 12, 2003), no costs for its use have been developed at this time.

This page left blank intentionally.

6.0 IMPLEMENTATION ISSUES

6.1 COST OBSERVATIONS

Not applicable (see Section 5.0).

6.2 PERFORMANCE OBSERVATIONS

The accuracy of the DH analyzer did not meet the performance objectives set for this demonstration primarily because of interferences from gases that include but may not be limited to hydrogen sulfide and methane. Further research into interference-resistant sensors or adsorbents capable of removing these interfering gases is recommended and is discussed further in Section 6.5.

6.3 SCALE-UP

The DH analyzer is an analytical technology and thus scale-up is more appropriately termed commercialization. Commercialization requirements are discussed in Section 6.5.

6.4 OTHER SIGNIFICANT OBSERVATIONS

Implementation of this technology will require investment in research and development to address the issues identified in Section 6.5. Interested parties can contact Dr. Patrick Evans at CDM. (See contact information presented in Appendix A.)

6.5 LESSONS LEARNED

These demonstrations showed that, while the DH analyzer is not yet ready for commercialization, with further development it can be a valuable tool for providing accurate field analyses of dissolved hydrogen. This further development needs to focus on:

- Modifying the existing hydrogen sensor or identifying a new sensor not sensitive to the dissolved gases found to interfere with DH detection in these demonstrations; increasing sensor stability, and eliminating the need to precondition
- Developing a system to detect leaks in the gas conveyance tubing/valving
- Improving mechanical stability
- Evaluating adsorbents capable of adsorbing hydrogen sulfide. The Carulite and molecular sieves used in the current DHA have some but insufficient hydrogen sulfide adsorption capacity. Alternative molecular sieves capable of adsorbing hydrogen sulfide are warranted. However, methane will likely still pose an interference problem and practical methane adsorbents do not exist. Thus identifying an alternative sensor is still necessary.

6.6 END-USER ISSUES

The main end-user (technical staff working on characterizing DoD sites) issue regarding use of a DH analyzer is: Will this instrument provide results comparable to those from the reference method? Since the demonstration results indicated that the DH analyzer results did not correlate well with the bubble-strip method, evaluating implementation issues would be premature. Further investigation into finding and testing a hydrogen sensor that does not negatively respond to other dissolved gases is needed before the DH analyzer can be further field demonstrated.

6.7 APPROACH TO REGULATORY COMPLIANCE AND ACCEPTANCE

Dissolved hydrogen is referenced in the EPA technical guidance on MNA of chlorinated solvents (EPA, 1998). Analysis of this analyte is not required at this time and is considered optional by regulatory agencies. Additionally, no field method for DH measurement has been approved by any regulatory agency, including the bubble-strip method.

With respect to execution of this project, minimal regulatory involvement was needed since this was a demonstration of analytical techniques, not remediation technology. Drilling permits were obtained as required by registered drillers under subcontract to CDM.

7.0 REFERENCES

- AGI Technologies. 1999. *Development of a Dissolved Hydrogen Analyzer and a Bioavailable Ferric Iron Assay*. Submitted to the Air Force Research Laboratory. October 1999.
- Battelle, 2000. *Technology Demonstration Plan: Reductive Anaerobic Biological in Situ Treatment Technology (RABITT) Treatability Testing at the East Gate Disposal Yard Site, Fort Lewis, WA*. May 2000.
- Chapelle, F.H., D.A. Vroblesky, J.C. Woodward, and D.R. Lovley. *Practical Considerations for Measuring Hydrogen Concentrations in Groundwater*. *Envir. Sci. Technol.* 31: 2873 – 2877, 1997.
- EA, *Final Site Specific Health and Safety Plan Monitoring Natural Attenuation Operable Unit 8 Submarine Base, Bangor, Washington*. October 30, 2000.
- EPA, *Technical Protocol for Evaluating Natural Attenuation of Chlorinated Solvents in Groundwater*. EPA/600/R-98/128. September 1998.
- Evans, P.J., 2001a. *Theory and Performance of a Field-Portable Dissolved Hydrogen Analyzer* In: *Natural Attenuation of Environmental Contaminants* (A. Leeson, M. Kelley, H.S. Rifai, and V.S. Mayar, eds.) Battelle Press, Columbus, OH, pp. 199-206, 2001.
- Evans, P.J., 2001b. *A Dissolved Hydrogen Analyzer and a Bioavailable Ferric Iron Assay for Bioremediation Analysis*. In: *Proceedings of the Second International Conference and Industrial Exhibition: Field Screening Europe, 2001*, pp. 139-144, 2001.
- Evans, P.J., 2001c. *Dissolved Hydrogen Analyzer*, U.S. Patent No. 6,277,329, 2001.
- NFESC and CDM, *Technology Demonstration Plan. Development of a Dissolved Hydrogen Analyzer and a Bioavailable Ferric Iron Assay*. ESTCP Project CU-0009. July 26, 2001.
- NFESC and CD, *Final Report. Field Demonstration and Validation of a Dissolved Hydrogen Analyzer*. ESTCP Project CU-0009. November 2004.
- USGS, *Monitoring Plan for Natural Attenuation Remediation, Waste Water Treatment Plant, Pensacola, Florida*. December 1999.

This page left blank intentionally.

APPENDIX A

POINTS OF CONTACT

POINT OF CONTACT Name	ORGANIZATION Name Address	Role In Project
Carmen A. Lebrón	NFESC Restoration Development Branch Code ESC411 1100 23rd Avenue Port Hueneme, CA 93043-4370	Principal Investigator
Dr. Patrick Evans	CDM 11811 NE 1 st Street, Suite 201 Bellevue, WA 98005-3033	Co-Principal Investigator
Dr. Frank Chapelle	USGS 720 Gracern Road, Suite 129 Columbia, SC 29210	Partner
Dr. Roger Olsen	CDM 1331 17 th Street, Suite 1200 Denver, CO 80202	Reviewer

This page left blank intentionally.

APPENDIX B BUBBLE-STRIP METHOD FOR ANALYZING DISSOLVED HYDROGEN

Measuring dissolved hydrogen is becoming more important in the evaluation of contaminated groundwater systems. Dissolved hydrogen is produced by fermentative microorganism under anaerobic concentrations. Respiring microorganisms then utilize DH in terminal electron-accepting processes. This process involves reducing terminal electron acceptors, such as CO₂, Fe (iii), and sulfate (Chapelle, 1997).

The bubble-strip method has proven to be a valuable and reliable method to measure DH and a wide range of different DH concentrations (Chapelle, 1977). The analysis generally takes 30 minutes.

The bubble-strip method consists of field sampling wells and laboratory analysis (EPA, 1998). Groundwater is continuously pumped at a rate of about 500 milliliters per minute (mL/min) through a 250-mL gas-sampling bulb. Gas (20-mL bubble of H₂-free N₂) is then introduced into the sampling bulb through the septum. Over time, hydrogen is transferred from the liquid to the gas phase, which some refer to as hydrogen being “stripped” from water. When equilibrium between the hydrogen in the liquid gas phase is established, a gas sample is taken and analyzed for hydrogen. The procedure generally takes 20 to 30 minutes (Chapelle, 1977).

The gas sample is then analyzed for hydrogen by gas chromatography with a reduction gas detector (EPA, 1998). Concentrations are then calculated from the following equation, assuming the DH concentration in the aqueous phase is in equilibrium with the gas phase (Chapelle, 1997).

$$C_{aq} = 0.812 C_{vap}$$

where C_{aq} is the aqueous concentration of DH in nanomolar (nM) and C_{vap} is the equilibrium vapor concentration of DH in parts per million (ppm) by volume.

The method should be used with a bladder, piston, or peristaltic pump. Use of a direct current driven submersible pump has the potential to generate DH and should not be used. In addition to different pumping systems, the method can also be affected by materials used in well construction (Chapelle, 1997). Metallic well casings can generate DH, but this effect is not seen with DH concentrations measured from polyvinyl chloride (PVC) wells (Chapelle, 1997).



ESTCP Program Office

901 North Stuart Street
Suite 303
Arlington, Virginia 22203
(703) 696-2117 (Phone)
(703) 696-2114 (Fax)
e-mail: estcp@estcp.org
www.estcp.org