

C-130 Transportability of Army Vehicles

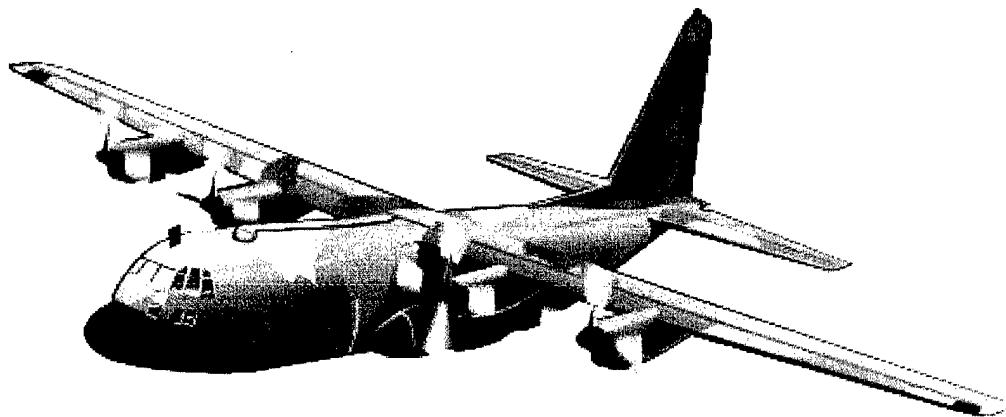

**Military Traffic Management Command
Transportation Engineering Agency
720 Thimble Shoals Boulevard
Suite 130
Newport News, VA 23606-4537**

**Joseph F. Cassidy
Cassidyj@tea-emh1.army.mil
(757) 599-1630
DSN 927-4646**

**DISTRIBUTION STATEMENT A
Approved for Public Release
Distribution Unlimited**

20010705 031

AQM01-08-1496

DEFENSE TECHNICAL INFORMATION CENTER
REQUEST FOR SCIENTIFIC AND TECHNICAL REPORTS

TITLE C-130 TRANSPORTABILITY OF ARMY VEHICLES .

<p>1. Report Availability (Please check one box)</p> <p><input checked="" type="checkbox"/> This report is available. (Complete section 2a - 2f)</p> <p><input type="checkbox"/> This report is not available. (Complete section 3)</p>	<p>2a. Number of Copies Forwarded</p> <p style="text-align: center;">1</p>	<p>2b. Forwarding Date</p> <p style="text-align: center;">8 JUN 01</p>
---	--	--

2c. Distribution Statement (Please check one box)

DoD Directive 5230.24, "Distribution Statements on Technical Documents," 18 Mar 87, contains seven distribution statements, as described briefly below. Technical documents MUST be assigned a distribution statement.

DISTRIBUTION STATEMENT A: Approved for public release. Distribution is unlimited.

DISTRIBUTION STATEMENT B: Distribution is authorized to U.S. Government Agencies only.

DISTRIBUTION STATEMENT C: Distribution is authorized to U.S. Government Agencies and their contractors.

DISTRIBUTION STATEMENT D: Distribution authorized to U.S. Department of Defense (DoD) and U.S. DoD contractors only.

DISTRIBUTION STATEMENT E: Distribution authorized to U.S. Department of Defense (DoD) components only.

DISTRIBUTION STATEMENT F: Further dissemination only as directed by the controlling DoD office indicated below or by higher authority.

DISTRIBUTION STATEMENT X: Distribution authorized to U.S. Government agencies and private individuals or enterprises eligible to obtain export-controlled technical data in accordance with DoD Directive 5230.25, Withholding of Unclassified Data from Public Disclosure, 6 Nov 84.

2d. Reason For the Above Distribution Statement (in accordance with DoD Directive 5230.24)

INFORMATION CONTAINED IN THE PAPER HAS ALREADY APPEARED IN SEVERAL PUBLICATIONS

<p>2e. Controlling Office</p> <p style="text-align: center;"><i>MTMCTEA MTTE-DPE</i></p>	<p>2f. Date of Distribution Statement Determination</p> <p style="text-align: center;"><i>8 JUN 01</i></p>
--	--

3. This report is NOT forwarded for the following reasons. (Please check appropriate box)

It was previously forwarded to DTIC on _____ (date) and the AD number is _____

It will be published at a later date. Enter approximate date if known. _____

In accordance with the provisions of DoD Directives 3200.12, the requested document is not supplied because: _____

<p>Print or Type Name</p> <p style="text-align: center;"><i>JOSEPH F. CASSIDY</i></p>	<p>Signature</p> <p style="text-align: center;"><i>Joseph F Cassidy</i></p>
---	---

<p>Telephone</p> <p style="text-align: center;"><i>(757) 599-1630</i></p>	<p>(For DTIC Use Only)</p> <p>AQ Number M01-08-1496</p>
---	---

C-130 Transportability of Army Vehicles

With Army Transformation well underway, and with the need for rapid deployment being a major factor in this transformation, the amount of Army combat equipment required to be transported by tactical aircraft could dramatically increase. Paramount in the requirements for both the Interim Armored Vehicle (IAV) and the Future Combat System (FCS) is the requirement for C-130 transport. While the C-130 has been used for years to transport Army troops and equipment, the new Brigade Combat Teams (BCT) will rely on it much more heavily to move into and around areas of operations. The weights and dimensions of the IAV and FCS are being driven by the need for C-130 transport. In fact, all BCT equipment will be required to be capable of C-130 transport.

The C-130, while an outstanding aircraft, does have operational limitations that should be considered by Army combat developers, materiel developers, planners, analysts, and decision-makers. The C-130's operational limitations are real and should be considered when designing equipment and planning operations. Prior MTMCTEA publications addressed maximum C-130 payload for limited ranges. This paper lays out C-130 characteristics that should be taken into consideration when designing future Army air transportable vehicles. To further assist the Army acquisition community, this document also provides greater detail on C-130 operational limitations for both normal and assault landings.

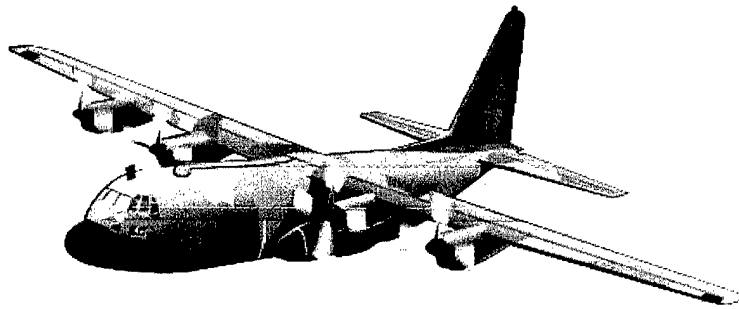

General:

The C-130 is a four-engine, high-wing, aft cargo door aircraft that is the Air Force's primary tactical transporter. The strategic, intertheater air transport required to deploy Army troops and equipment from CONUS to other areas of the world, is the responsibility of the C-5, C-17, C-141, and Civil Reserve Air Fleet (CRAF). The C-130, and in some situations the C-17, is used once the troops and equipment arrive in theater. While the C-130 has been around since the first C-130A entered the inventory in 1956, the aircraft has continually been upgraded. The latest version, the C-130J, has just begun entering the inventory. The cargo compartment of the C-130J is the same size as that of the C-130E/H. The stretch version of the C-130J, the C-130J-30, will have the same cargo compartment cross section, but will have a longer fuselage. The additional length

will accommodate two additional 463L pallets. Most of the current inventory is comprised of various configurations of the E and H models. The Air Force is working to consolidate these various E and H configurations into one C-130X configuration. With the exception of some special mission aircraft (MC-130s, EC-130s, AC-130s, etc.), the USAF C-130 does not have an aerial refueling capability. The C-130J was designed with the internal piping required for aerial refueling, but there are no current plans to field an aerial refueling capability.

Range and Payload:

General:

The C-130E/H has a maximum range of 2,800 nautical miles, carrying no payload. The maximum payload is 45,000 pounds, with a range of only about 240 nautical miles. The amount of payload that a C-130 can transport is a function of many factors. Most Army personnel probably are familiar with the range-payload curves that accompany aircraft manufacturer's presentations at trade shows. These curves represent the theoretical maximum capability; they do not take into consideration the Air Force's practical operational limitations nor do they account for environmental or geographical conditions. As a result of the criticality of IAV and FCS C-130 transport, MTMCTEA has compiled operational, rather than planning, numbers for the C-130, with a goal of MTMCTEA, as the Army Transportability Agent, disseminating these criteria throughout the Army.

The most readily apparent factor involved in the amount of payload carried is how far the Army needs the payload transported. The range of the aircraft is affected by the aircraft's total weight, consisting of aircraft, crew, equipment, fuel, and cargo. Cargo consists of the passengers, equipment, and any wood shoring required under the equipment. Other factors in determining how far and how much can be carried include temperature, airfield elevation, density altitude, wind speed and direction, precipitation, runway slope, and the individual aircraft's history.

Moreover, once the cargo weight is above 36,500 pounds, the aircraft MUST land with additional fuel FOR STRUCTURAL REASONS. At a cargo weight of 38,000 pounds the landing fuel is 7,000 pounds, for 40,000 pounds of cargo it increases to 12,000 pounds, and 42,000 pounds of cargo requires 16,000 pounds of landing fuel. This fuel must be considered as UNUSABLE; therefore, increases in weight above 36,500 pounds require a disproportionate increase in the landing fuel required, with a subsequent decrease in range.

Normal Landings:

The C-130 can fly a 38,000-pound payload 1,000 nautical miles (the IAV requirement), into a 5,000-foot improved airfield on a standard day at sea level with no corrections for wind, rain, runway slope, and so forth. Similarly, it can fly a 40,000-

pound payload about 780 nautical miles and a 42,000-pound payload about 560 nautical miles under the same conditions.

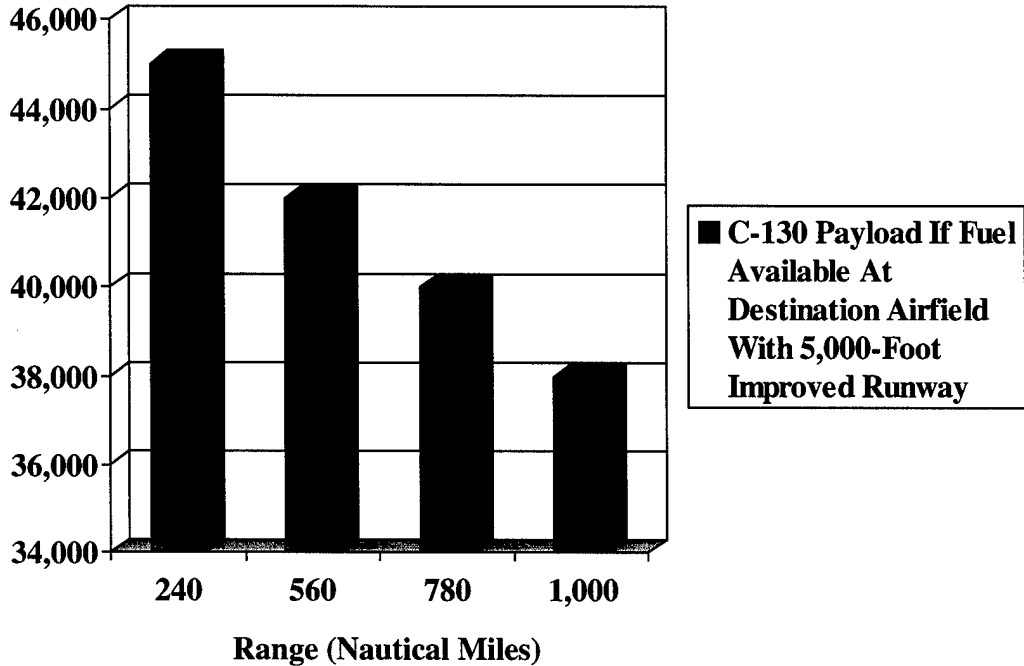

A key point about these particular ranges and payloads that must be considered is that fuel for the aircraft must be available at the destination airfield. If fuel is not available, the maximum payload of the aircraft decreases significantly since enough fuel must exist to allow the aircraft to depart and reach a recovery base (a recovery base 100 nautical miles away would require approximately 4,500 pounds more fuel). This additional fuel will cut into either the aircraft range or payload allowed. For comparison purposes, the map below shows straight line distances from Washington DC. Chicago is about 500 nautical miles and Dallas is about 1,000 nautical miles from Washington DC.

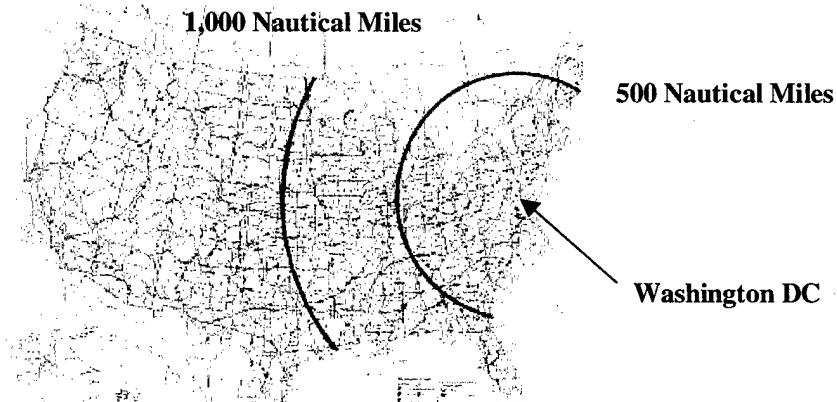

Assault Landings:

Landing a C-130 at the ranges and payloads discussed earlier requires a runway length of at least 5,000 feet and a runway width of at least 80 feet. At these runway lengths and widths, the C-130 landing weight could be 155,000 pounds. Landings on shorter or narrower runways would require an assault landing. Assault landings require a runway length of at least 3,000 feet and a runway width of at least 60 feet. The assault landing maximum total landing weight for a C-130 is only 130,000 pounds. This is because an assault landing onto a short assault zone results in a firmer impact with the ground, stressing the aircraft wing structure more than a normal landing. For structural reasons, therefore, assault landings are limited to a maximum aircraft weight of 130,000 pounds. Given this maximum weight, and an aircraft weighing 86,500 pounds, only the remaining 43,500 pounds is available for fuel and payload. With 7,000 pounds of fuel typically required during landing in case the aircraft needs to divert to another airfield to land, the amount of available payload would be 130,000 pounds minus 86,500 pounds minus 7,000 pounds, or 36,500 pounds. These are peacetime assault landing restrictions.

Landings at weights greater than 130,000 pounds can be waived only by a Major Air Force Command Director of Operations. Instances of waivers being granted are extremely rare.

C-130 Maximum Peacetime Assault Landing Weight

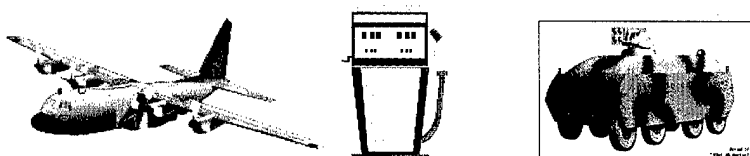

$$86,500 + 7,000 + 36,500 = 130,000 \text{ pounds}$$

Aircraft Fuel Must Be Available At The Destination Airfield

MTMCTEA, in publishing transportability criteria used by the Army acquisition community, only published a maximum payload of 42,000 pounds for a limited range mission. To assist the Army acquisition community with design of future combat systems, this document provides greater detail on C-130 operational limitations for both normal and assault landings.

As can be seen, the C-130 can be limited in certain operational scenarios. If flight or airfield conditions are less than ideal, then range-payload numbers will be less than ideal. Designing equipment to the maximum range-payload capability of the aircraft will

increase the risk that the equipment won't be capable of transport for the required distance some percentage of the time.

It must be emphasized that if range is sacrificed for increased cargo weight, then the need for intermediate fueling stops increases, resulting in an increase in the total time required to move the vehicles from point A to point B. During a mass movement of vehicles, where each C-130 is needed for multiple shuttles, this increased movement time results in either a later closure time or the need for additional C-130s. Another concern is the acquisition of a vehicle that requires more than one C-130 to move it (vehicle partially disassembled). In this case, as in the previous decreased range discussion, the additional C-130s required may stress the Defense Transportation System (DTS) beyond its capabilities. There are myriad operational scenarios that could be discussed (i.e. lack of en-route refueling locations) but suffice it to say that serious consideration should be given to maximum transportation flexibility as the impact on the DTS is balanced against the warfighter's vehicle needs.

Vehicle Weight:

Another area of concern for air transport is the natural tendency of equipment designers to try to get as much capability as possible into a small package. This often results in a vehicle design that exceeds the capability of the aircraft. The solution most often put forward by designers is to rely upon modularity or disassembly to get their vehicle into the aircraft. The major part of the vehicle would go into one aircraft and the crew and removed equipment would go into a second aircraft. Once both aircraft were unloaded, the crew would reassemble the vehicle. The tactical acceptability of this concept is scenario dependent and not the subject of this writing. The need for an additional aircraft, however, does increase the number of missions required to get the deploying force on the ground. The number of C-130s that the Air Force can dedicate to Army missions probably will not increase. If the complete vehicle and crew fit into one aircraft rather than two, then the use of this air resource would be made much more efficient. Also a consideration is the impact that additional aircraft would have when the destination airfield is MOG (Maximum On Ground) constrained or requires Arrival Airfield Control Group (AACG) support personnel.

Another factor in the one versus two aircraft scenario is Murphy's Law. "If anything can go wrong it probably will." The air transport world, much like the rest of the world, is subject to this law. While the C-130 is extremely reliable, and we are fairly successful at predicting the weather, events happen that are out of our control. Many scenarios are possible. The most likely scenario is that each aircraft arrives on time, the crew reassembles the vehicle, and the vehicle and crew drive away. However, the crew could arrive without the vehicle. The vehicle could arrive without the crew. Both aircraft could arrive, but one could be diverted to a secondary field. The ideal vehicle design with the assembled vehicle and crew on the same aircraft would tend to minimize the applicability of Murphy's Law.

Why is C-130 air transport suddenly an issue? The C-130 has been around for over 40 years and has been successfully carrying Army equipment all this time. The current issue is driven by the size and weight of the new equipment and the increase in the amount of Army combat equipment required to be transported by tactical aircraft. The FCS requirements allow the system to weigh up to 40,000 pounds. The heaviest current Army C-130 certified armored vehicle is the M9 Armored Combat Earthmover (ACE) (35,500 pounds), certified for C-130 transport at 38,000 pounds. The ACE, however, is not the type of vehicle that would most likely be deployed as a power projection vehicle.

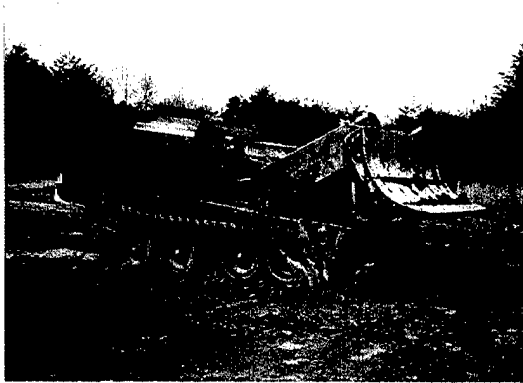

M-9 ACE

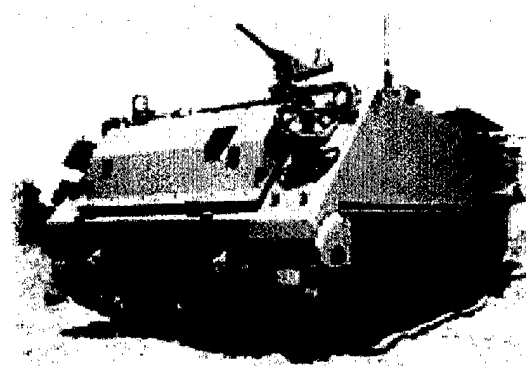

M1064A3

Vehicles mounted on the M113 chassis are the heaviest Army armored vehicles that currently fit this description. The M113A3 (23,880 pounds), M1064A3 (27,635 pounds), and M1068A3 (25,650 pounds) have been certified for C-130 air transport at 31,000 pounds, the M113 chassis rating. The Marine Corps' family of Light Armored Vehicles (LAV) are C-130 transportable, being certified by the Air Force at a maximum weight of 36,000-pounds and a maximum axle load of 10,000 pounds. While certified to a maximum of 36,000 pounds, the heaviest USMC LAV developed, the LAV-105, weighs 30,500 pounds.

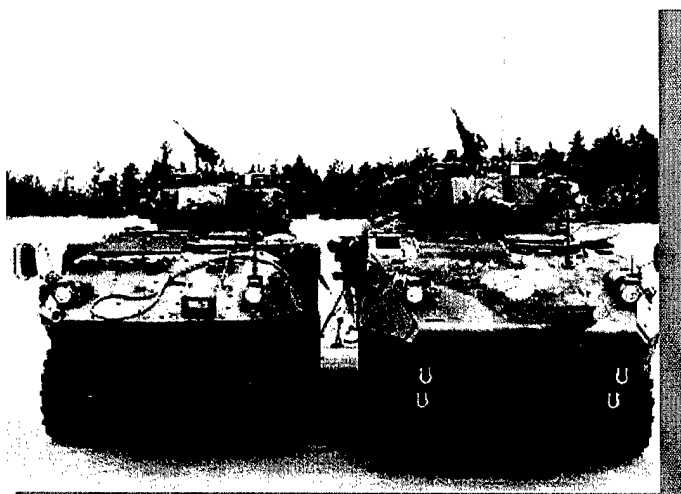

LAV-25 and LAV III

Dimensional Limitations:

The interior of the C-130 also has limitations. The design guidance published in MIL-HDBK-1791, Designing for Internal Aerial Delivery in Fixed Wing Aircraft, establishes an equipment design envelope of 102 inches high by 107 inches wide by 480 inches long. These dimensions allow six inches of safety clearance between the top and sides of the equipment and the aircraft structure. The 102-inch design height leaves room for the almost inevitable wood shoring required under combat vehicles. Depending on the specifics of each piece of equipment, the Air Force can encroach somewhat upon its safety clearance areas, under special circumstances, having certified equipment and shoring up to 105 inches high.

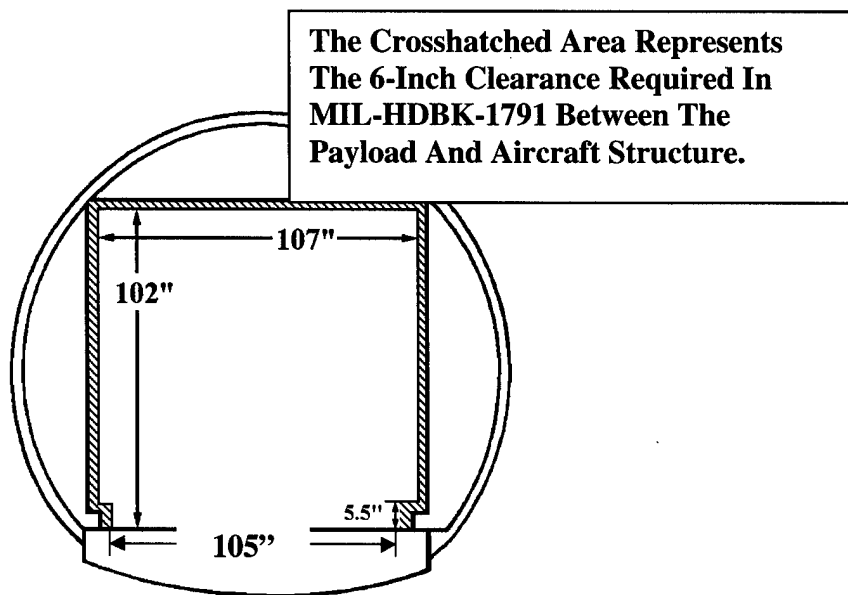

C-130 Design Envelope

The width between the permanently installed roller conveyor rails of 105 inches up to a height of 5.5 inches is also specified. This does not mean that the Air Force will certify vehicles that are 105 inches wide at the floor. Loading vehicles into the C-130 is not a fast operation and requires close coordination between the vehicle driver, ground guides, and the aircraft loadmaster to ensure that the vehicle is loaded straight into the aircraft without touching the rails. Part of the loading process is an operational preference to have vehicles backed into, rather than driven into, the aircraft. This is done to expedite off-loading at forward airfields. Contact between vehicle tracks or wheels could damage the rails. Proper operation of these rails is key to the C-130's alternate missions of airlifting cargo pallets and for airdrop. The Air Force, therefore, is very protective of these rails. The practical maximum width for a tracked vehicle at the floor is 100 inches, although the Air Force would prefer no more than 98 inches. The practical maximum for a wheeled vehicle at the floor is 102 inches. The maximum width

for any vehicle could be much less if the steering is insensitive or if the vehicle can not be accurately steered. Combat vehicles that exceed these practical maximums probably will require about 6 inches of wood shoring to protect the rails. This wood shoring counts as payload, with 6 inches of shoring weighing about 1,800 pounds, and also reduces the available height by six inches.

MIL-HDBK-1791 also specifies the need for a safety aisle in either of the two configurations shown below. Safety aisle "A" is 14 inches wide and extends from a point no more than 36 inches above the aircraft floor all the way up to the aircraft ceiling. Safety aisle "B" is 30 inches wide and extends from a point no more than 60 inches above the aircraft floor all the way up to the aircraft ceiling. The safety aisle is required so the aircraft loadmaster (with full gear, helmet, and parachute) or the flight crew can get by the equipment and reach the aft end of the aircraft in an in-flight emergency. Infrequent air transport requirements and a host of old vehicle designs coupled with wartime mission needs often led the Air Force to overlook the safety aisle as a low risk assessment. However, with BCT vehicles planned to be air transported in large numbers and increasing frequencies, the risk has increased. *The Air Force will enforce the safety aisle for all new equipment.* Army designers who fail to meet the safety aisle requirements may end up with equipment that will not be certified for C-130 transport.

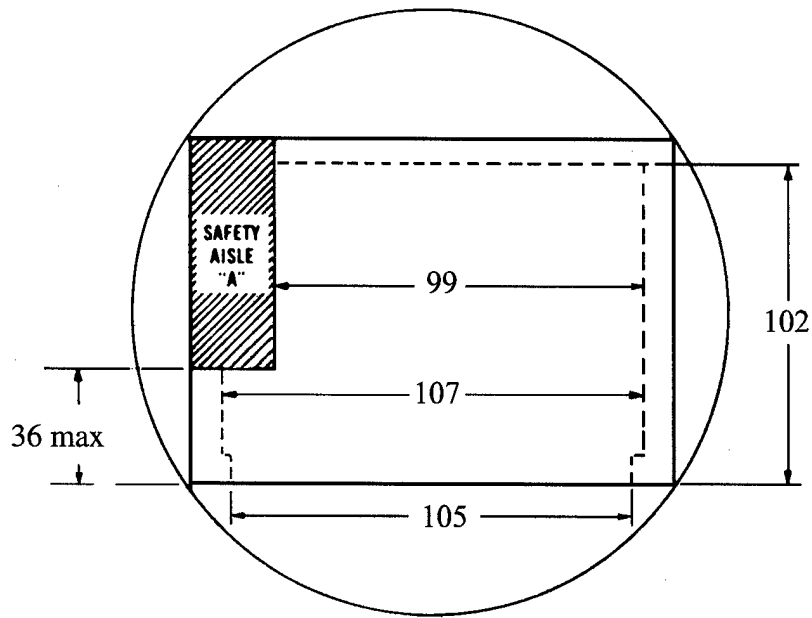

Dimensions in inches

Safety aisle options

- A. Side aisle 14 X 72
- B. Top aisle 30 X 48

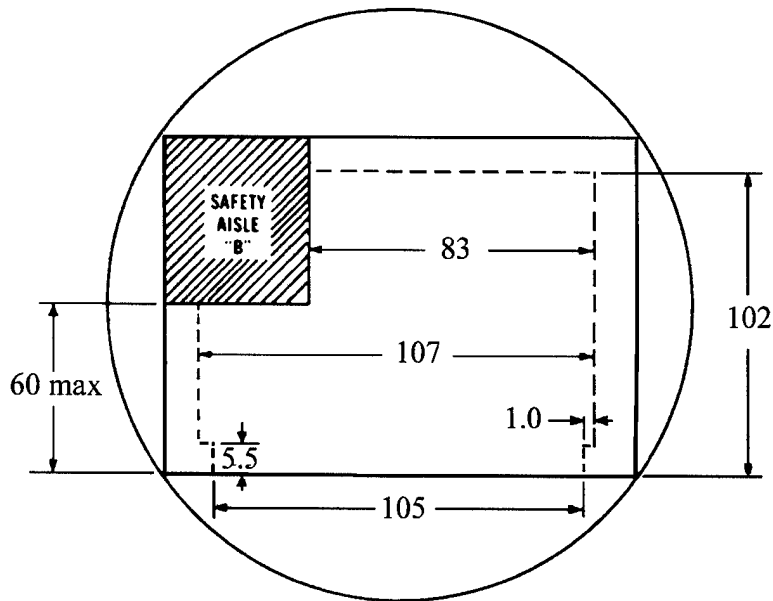

C-130 Loadmaster Safety Aisles

On flights where passengers are being carried, Air Force Instruction 11-2C-130, Volume 3, Addenda A, Flight Operations, C-130 Operations Configuration/Mission Planning, 1 April 2000 requires a 14-inch-wide passenger safety aisle beginning at the floor between the left wheel well wall and any cargo to provide access to emergency exits. For safety aisle purposes, the Air Force has specified that Army crew members accompanying their vehicle would be considered passengers. This 14-inch-wide passenger safety aisle requirement may eliminate some Army vehicle crew members from flying on the same aircraft as their vehicle.

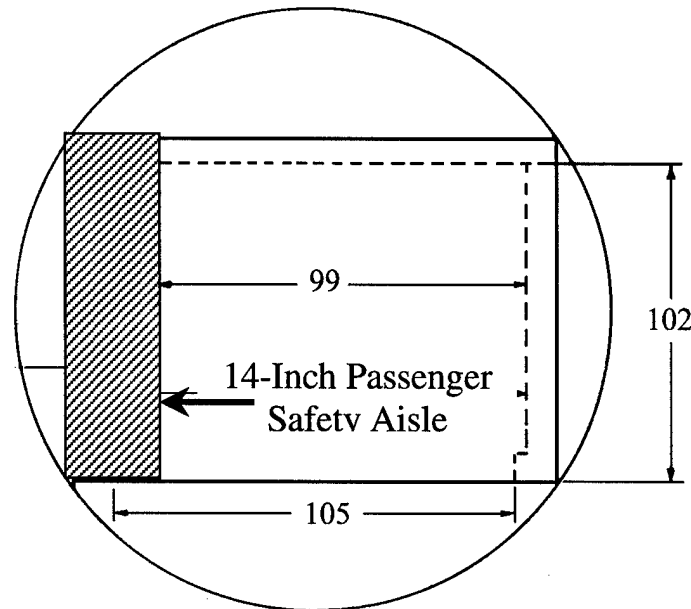

C-130 Passenger Safety Aisle

With a 14-inch safety aisle on the left and a 6-inch clearance on the right, the width available for a vehicle accompanied by crew members is 99 inches. This ignores the clearance requirement between the wheels or tracks and the right rail. If we assume a wheeled vehicle would have the minimum practical clearance between the wheels and the right rail of 1.5 inches, then the widest the vehicle could be at the floor would be 97.5 inches. The 2.5-inch minimum practical clearance at the floor between a tracked vehicle and the right rail would give a maximum tracked vehicle width at the floor of 96.5 inches.

How does this impact Army passengers accompanying their equipment? Cargo trucks and HMMWVs are typically not a problem, but wide track combat vehicles may be forced to the centerline of the aircraft, further impacting the safety aisle. The 14-inch-wide passenger safety aisle is an Air Force Instruction 11-2C-130 requirement. Flying of Army passengers accompanying their combat vehicles during wartime would require a waiver of the requirement. In all cases where safety aisle access does not meet the published requirements, the Air Force could require a timed access test to assess risk.

Floor Strength (See Attachment B):

The third area to which equipment designers must pay particular attention is the aircraft's floor strength. The new C-130J and C-130J-30 will have the same floor strength as the older C-130s. The floor strength limitations are:

- For wheeled vehicles, the 35-inch-wide treadways are rated at 13,000 pounds (axle load) in the central part (28.75 feet) of the aircraft (fuselage station 337 to 682) for both loading and flight, provided the tire pressure is less than 100 pounds per square inch. The allowable load on each tire is one-half the axle-load rating.
- The treadways in the rest of the aircraft are rated at 13,000 pounds for loading and 6,000 pounds for flight. (The maximum axle load on the ramp for flight is 3,500 pounds.) This allows vehicles to reach the high strength area during loading. The 13,000 pound axle load limit applies not only to static loads, but also to transient loads encountered during aircraft loading. For example, some four-axle vehicles do, at times, unload a fourth axle during ramp cresting, momentarily increasing the remaining axle weights on the aircraft to greater than 13,000 lbs. This overload, no matter how momentary, is unacceptable; *the Air Force position is that the 13,000-pound limit is firm, regardless of location and duration.*
- For tracked vehicles, the treadways are rated at 6,000 pounds per linear foot (3,000 pounds per side) of linear track length in contact with the aircraft floor in the central part of the aircraft (fuselage station 337 to 682).
- The treadways in the rest of the aircraft are rated at 6,000 pounds per linear foot for loading and 2,800 pounds (1,400 pounds per side) for flight. This allows vehicles to reach the high strength area during loading.
- *The maximum concentrated load allowed on the aircraft floor is 50 pounds per square inch.* For wheeled vehicles, this is calculated by determining the area of the tire contact area, usually measured by tracing the ellipse formed between the tire and the ground. The weight on the tire is divided by the number of square inches in the ellipse to arrive at the ground contact pressure. For tracked vehicles, the weight of the heaviest road wheel is divided by the area of the track pad under that road wheel.

Vehicle Design:

From a transportability engineering perspective, the design of future combat vehicles needs to take the operational realities of the C-130 into consideration. Where possible, serious consideration needs to be given to the C-130's peacetime assault landing weight of 130,000 pounds. Because of the stresses experienced by the airframe at weights above 130,000 pounds, counting on the Air Force to grant a waiver to the maximum assault landing weight during wartime could be risky. A maximum vehicle weight of 29,000 pounds would allow an empty aircraft to recover to an airfield about 250 nautical miles away. A vehicle weight of 32,000 pounds would allow an empty

aircraft to recover to an airfield about 100 nautical miles away. *If one considers maximum transportation flexibility to be of paramount importance, the maximum C-130 air transport weight of future vehicles should be in the 29,000- to 32,000-pound range. These weights ideally would include the crew, ¾-tank of fuel, and full ammunition, armor, and equipment.* The C-130's mission profile requirements would need to be established by the Army, in coordination with the Air Force, before a maximum weight requirement could be determined. *If the vehicle's mission allows the aircraft to be refueled at the payload's destination, then the maximum C-130 assault landing air transport weight could be as high as 36,500 pounds.*

The vehicle should incorporate the C-130's passenger safety aisle requirement into its design. The ideal design would allow for a vehicle to be centrally loaded in the lateral direction in the aircraft. This would limit the vehicle's width to 91 inches. The maximum vehicle width, based upon an asymmetrical loading, would be 99 inches at the vehicle's widest point and 97.5 inches wide at the floor for a wheeled vehicle (96.5 inches wide at the floor for a tracked vehicle). The ideal maximum height would be 90 inches. This would allow the vehicle to fit within the C-130's airdrop design envelope for vehicles with suspension systems. *While the Air Force has certified vehicles up to 105 inches high, the maximum height should be no more than 102 inches, depending on where the 102-inch height occurs on the vehicle, to allow for the inevitable shoring and to minimize loading and unloading times.*

Currently, the granting of waivers for safety aisles is accomplished on a case-by-case basis. An evaluation by the Air Force would be required on an acquisition program-by-acquisition program basis, and possibly could not be completed until a vehicle is available for testing.

Summary and Conclusions:

This was a summary of C-130 operational limitations that don't always appear in design handbooks and manufacturer advertising. In the transportability arena, it's much better to take a few minutes to double check the design while still working on concepts. One of the maxims of transportability engineering is that no matter how combat capable a piece of equipment or unit may be, if it can't be transported rapidly to a conflict, when needed, then that capability is diminished.

With the increased use of the C-130 for the Army of the future, a thorough understanding of the operational limitations of the aircraft is prudent. If flight or airfield conditions are less than ideal, then the C-130's range and payload numbers will be less than ideal. Designing equipment to the maximum capability of the aircraft will increase the risk that the equipment may not be capable of transport for the required distance some percentage of the time.

The natural tendency of equipment designers to try to get as much capability as possible into a small package can lead to C-130 transport problems. This is because the typical solutions rely upon modularity or disassembly to meet the aircraft limits, with the

major part of a vehicle going into one aircraft and the crew and removed equipment going into a second aircraft. This need for an additional aircraft increases the number of missions required to get a deploying force on the ground, thus increasing force closure timelines. The negative impact that additional aircraft would have when the destination airfield has a limited capability is very real.

The design of combat vehicles for C-130 transport should be based upon the operational limitations, not on the maximum capabilities, of the aircraft. From an ideal transportability perspective, vehicles that are C-130 transportable would include the aircraft being capable of landing at all austere airfields onto which it is capable of landing and taking off again without the logistic burden of having to refuel before takeoff. This means combat vehicles (including armor, fuel, ammunition, equipment, and crew) weighing 29,000 to 32,000 pounds that can roll off the aircraft ready to fight. If at all possible, at least the vehicle driver should accompany the vehicle to ensure the vehicle can be offloaded at destination.

Acknowledgement: The author gratefully acknowledges the Air Mobility Command's DOV staff as well as Lloyd R. Cato and Owen Spivey of MTMCTEA's Deployability Engineering Team, without whose assistance this paper would not have been possible.

Joseph F. Cassidy
MTMCTEA (MTTE-DPE)
DSN 927-4646
15 March 2001

ATTACHMENT A

Maximum Recommended Vehicle Design Limits For C-130 Transport
(Based on 1,000 NM flight under optimum conditions)

Measure	Vehicle Crew Accompanying Vehicle (Passenger Safety Aisle Enforced By Air Force)		Vehicle Crew Not Accompanying Vehicle (Or Air Force Grants Waiver To Passenger Safety Aisle Requirement)	
	Normal Landing	Assault Landing	Normal Landing	Assault Landing
Weight (pounds)	38,000	36,500*	38,000	36,500*
Axle Load (pounds)	13,000	13,000	13,000	13,000
Overall Width (inches)	99	99	107	107
Width At Floor (Wheeled)	97.5	97.5	102	102
Width At Floor (Tracked)	96.5	96.5	100	100
Height (inches)	102	102	102	102
Floor Loading (Pounds Per Linear Foot)	6,000	6,000	6,000	6,000
Floor Loading (Pounds Per Square Inch)	50	50	50	50

* Assumes fuel available at offload airfield. If fuel is assumed not to be available, vehicle weight must be reduced to allow enough fuel to be "tankered" to allow takeoff & flight to refueling airfield.

Maximum Recommended Vehicle Design Limits For C-130 Transport
(Based on 560 NM flight under optimum conditions)

Measure	Vehicle Crew Accompanying Vehicle (Passenger Safety Aisle Enforced By Air Force)		Vehicle Crew Not Accompanying Vehicle (Or Air Force Grants Waiver To Passenger Safety Aisle Requirement)	
	Normal Landing	Assault Landing	Normal Landing	Assault Landing
Weight (pounds)	42,000	36,500*	42,000	36,500*
Axle Load (pounds)	13,000	13,000	13,000	13,000
Overall Width (inches)	99	99	107	107
Width At Floor (Wheeled)	97.5	97.5	102	102
Width At Floor (Tracked)	96.5	96.5	100	100
Height (inches)	102	102	102	102
Floor Loading (Pounds Per Linear Foot)	6,000	6,000	6,000	6,000
Floor Loading (Pounds Per Square Inch)	50	50	50	50

* Assumes fuel available at offload airfield. If fuel is assumed not to be available, vehicle weight must be reduced to allow enough fuel to be "tankered" to allow takeoff & flight to refueling airfield.

ATTACHMENT B

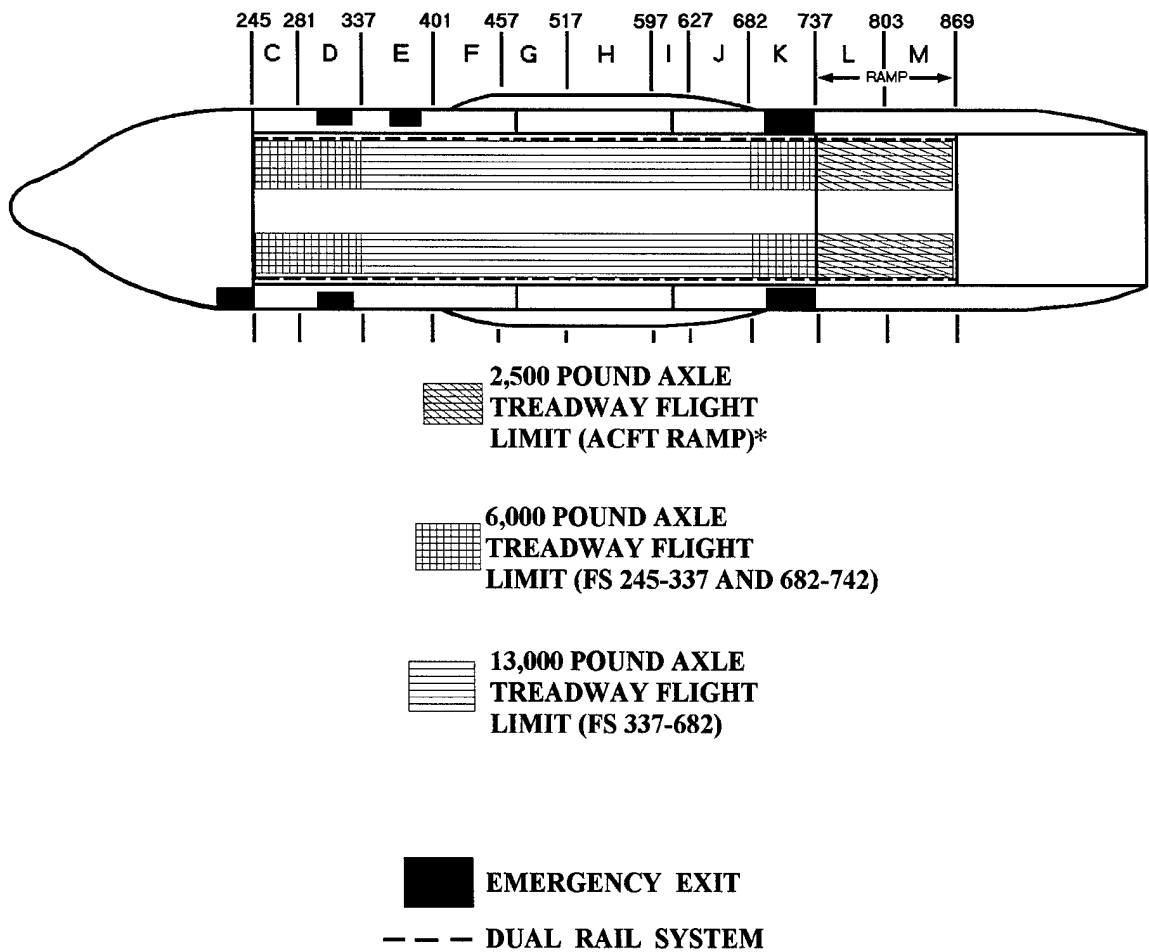
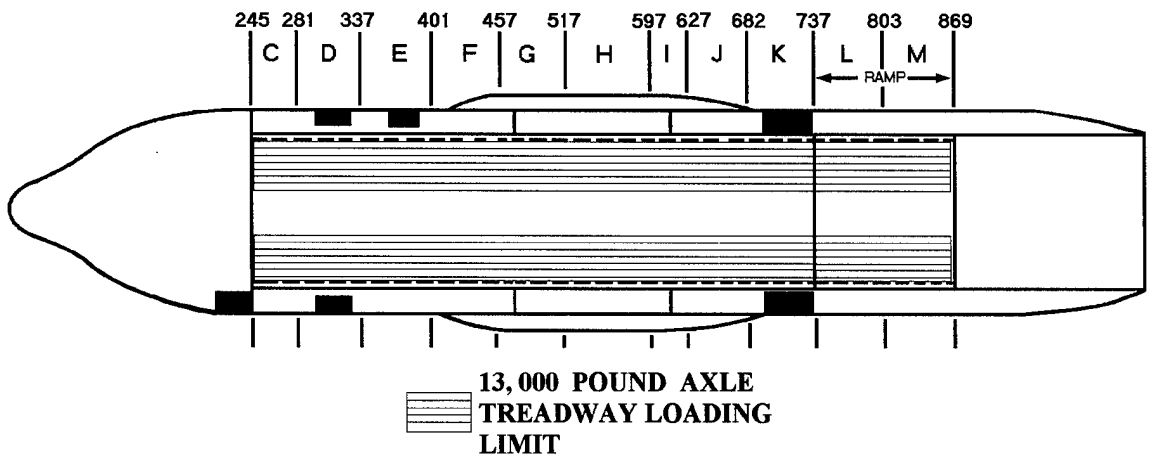

* For E and H models only, if there is one single axle, and nothing else, on the ramp, the weight limit for flight can be raised to 3,500 pounds.