

UNCLASSIFIED
SECURITY CLASSIFICATION OF THIS PAGE

AD-A190 999

REPORT DOCUMENTATION PAGE

1. REPORT SECURITY CLASSIFICATION <u>Unclassified</u>		1b. RESTRICTIVE MARKINGS	
1. SECURITY CLASSIFICATION AUTHORITY		3. DISTRIBUTION / AVAILABILITY OF REPORT Approved for public release; distribution unlimited.	
1. DECLASSIFICATION / DOWNGRADING SCHEDULE		5. MONITORING ORGANIZATION REPORT NUMBER(S) <u>ARO 23208.1-CH</u>	
PERFORMING ORGANIZATION REPORT NUMBER(S)		7a. NAME OF MONITORING ORGANIZATION U. S. Army Research Office	
1. NAME OF PERFORMING ORGANIZATION SRI International	6b. OFFICE SYMBOL (if applicable)	7b. ADDRESS (City, State, and ZIP Code) P. O. Box 12211 Research Triangle Park, NC 27709-2211	
2. ADDRESS (City, State, and ZIP Code) 333 Ravenswood Avenue Menlo Park, CA 94025		9. PROCUREMENT INSTRUMENT IDENTIFICATION NUMBER <u>DAAG29-85-K-0186</u>	
8a. NAME OF FUNDING / SPONSORING ORGANIZATION U. S. Army Research Office	8b. OFFICE SYMBOL (if applicable)	10. SOURCE OF FUNDING NUMBERS	
8c. ADDRESS (City, State, and ZIP Code) P. O. Box 12211 Research Triangle Park, NC 27709-2211		PROGRAM ELEMENT NO.	TASK NO.
11. TITLE (Include Security Classification) <u>Immobilized 4-Dialkylaminopyridines: Supernucleophilic Chemical Decontaminating Systems</u>		PROJECT NO.	WORK UNIT ACCESSION NO.
12. PERSONAL AUTHOR(S) Subhash C. Narang and Susanna Ventura			
13a. TYPE OF REPORT Final	13b. TIME COVERED FROM: <u>7/1/85</u> TO: <u>9/30/87</u>	14. DATE OF REPORT (Year, Month, Day) 1987/12/22	15. PAGE COUNT 19
16. SUPPLEMENTARY NOTATION The view, opinions and/or findings contained in this report are those of the author(s) and should not be construed as an official Department of the Army position, policy, or decision, unless so designated by other documentation.			
17. COSATI CODES		18. SUBJECT TERMS (Continue on reverse if necessary and identify by block number)	
FIELD	GROUP	Supernucleophiles, Hydrolysis, Decontamination, Polymers	
19. ABSTRACT (Continue on reverse if necessary and identify by block number) Supernucleophilic polymers containing the 4-dialkylaminopyridine moiety were synthesized by different methods, either by modification of the polymers or by polymerization of methacrylamides. The resulting polymers show good catalytic activity for hydrolysis of acetate esters. The catalytic activity can be changed readily by modifying the polymer structure. <i>Key words:</i>			
20. DISTRIBUTION / AVAILABILITY OF ABSTRACT <input type="checkbox"/> UNCLASSIFIED/UNLIMITED <input type="checkbox"/> SAME AS RPT. <input type="checkbox"/> DTIC USERS		21. ABSTRACT SECURITY CLASSIFICATION Unclassified	
22a. NAME OF RESPONSIBLE INDIVIDUAL		22b. TELEPHONE (Include Area Code)	22c. OFFICE SYMBOL

DTIC
SELECTED
FEB 02 1988
S D

SRI International



IMMOBILIZED 4-DIALKYLAMINOPYRIDINES: SUPERNUCLEOPHILIC CHEMICAL DECONTAMINATING AGENTS

Final Report

By: Subhash C. Narang and Susanna Ventura

December 1987

U.S. ARMY RESEARCH OFFICE

Contract No. DAAG29-85-K-0186

SRI Project PYU-8872

Approved for public release; distribution unlimited.

88 1 27 094

333 Ravenswood Ave. • Menlo Park, CA 94025
415 326-6200 • TWX: 910-373-2046 • Telex: 334-486

PREFACE

SRI International has conducted a program of research for the Army Research Office under Contract No. DAAG29-85-K-0186. The work during two years of effort has included tasks on the synthesis of supernucleophilic polymers, their ability to catalyze hydrolysis of carboxylate esters, and their utilization in corrosion inhibition studies.

The latest results are summarized and the previous results are included as an appendix. The appendix is a preprint of an article to be published in the American Chemical Society Symposium series.



Accession For	
NTIS CRA&I	<input checked="" type="checkbox"/>
DTIC TAB	<input type="checkbox"/>
Unannounced	<input type="checkbox"/>
Justification	
By	
Distribution/	
Availability Codes	
Dist	Avail and/or Special
A-1	

During the last reporting period, we have concentrated on examining the corrosion inhibition efficiency of supernucleophilic polymer coatings.

It is well known that at high operating temperatures halide ions such as chloride and bromide ions are extremely aggressive toward corrosion of many containment materials such as steel, stainless steel, and copper. The type of corrosion exhibited by these metals in strong salty aqueous environments containing oxygen is pitting. Pitting corrosion is one of the most severe types of corrosion.

Three basic methods can be used to combat corrosion problems of this nature. They are (a) choose a more corrosion-resistant material (which in many cases is economically unattractive), (b) use a corrosion-resistant coating (which is likely to fail with many commonly used inexpensive coating materials because of the temperature cycling involved), and (c) use adsorption type synergistic corrosion inhibitors stable up to 230°C. Among these, the use of adsorption type synergistic corrosion inhibitors appears to be the most attractive approach in terms of both effectiveness and cost. It was shown that the synergistic inhibitors developed by us at SRI perform better at higher halide concentrations.

The initial step in this mechanism is the adsorption of chloride ions on the metal surface. This adsorption, which is often called "specific adsorption," creates an excess negative charge on the metal surface, which in turn attracts the quaternary cations by purely electrostatic forces, as shown in Figure 1. These adsorbed quaternary cations containing bulky organic groups then cover the metal surface effectively, protecting it from corrosion. The ability to protect the metal from corrosion is largely dependent on the size, structure, electronic, and dielectric properties of the bulky organic groups attached to the quaternary cation.

Because the extent of adsorption of chloride ions depends on the chloride ion concentration in solution, an increasing chloride content inhibits the corrosion of the metal more effectively, as shown in Figure 2. The synergistic chloride-ion-induced corrosion inhibition is effective even in high chloride-containing solutions, as shown in Figure 3. These preliminary investigations conducted at SRI¹ indicate that appropriately substituted quaternary compounds form an excellent group of corrosion inhibitors for large structural applications, even on corroded surfaces. When applied on a corroded surface, these inhibitors reach the metal surface by moving through the corrosion products because of their inherent surfactant^{2,3} properties. In addition, they also have good antibacterial properties,^{2,3} thus demonstrating their multifunctionality.

Preliminary experiments conducted under an IR and D program at SRI show that quaternary ammonium salts based on N-methylnaphthyl pyridinium chloride derived from supernucleophilic pyridines form an excellent group of corrosion inhibitors having synergistic action. Figure 4 illustrates the effect of two synergistic-type corrosion inhibitors, N-methylnaphthyl quinolinium chloride (NMNQC) and N-methylnaphthyl piperidino pyridinium chloride (NMNPPC), in inhibiting the corrosion of steel in 0.5 M H₂SO₄ + 10% HCl. Clearly, the R_p values (low frequency intercept of the Nyquist plot) obtained with the inhibitor are much larger than in the absence of the inhibitor. Because the corrosion rate of the metal is inversely proportional to R_p, the strongly acid chloride environment containing NMNQC and NMNPPC provides excellent corrosion inhibition to the steel because of the large R_p values of these groups. NMNQC provides an inhibitor efficiency of 85%, whereas NMNPPC provides an efficiency of 89%.

Based on these results, we have synthesized polymeric coatings⁴ containing the 4-dialkylaminopyridine moiety quarternized with 1-chloromethylnaphthalene. This coating shows inhibition of corrosion of metal surfaces under high halide concentrations. However, the coating is not as effective as the monomeric species in this regard. New

polymeric backbones are being explored to achieve better corrosion inhibition using supernucleophilic polymers.

REFERENCES

1. S. Hettiarachchi and S. Narang, SRI International Research and Development Project 32JD32/SSB (1986).
2. V. N. Kushnir, Yu L. Volyanskii, and M. I. Shevchuk, *Khim-Farm. ZL.*, 14, 45 (1980).
3. R. Vilceanu and A. Venezel, *Rev. chim. (Bucharest)*, 32, 327 (1981).
4. S. Hettiarachchi and S. Narang, SRI International Research and Development Project 870D32/XDD (1987), in progress.

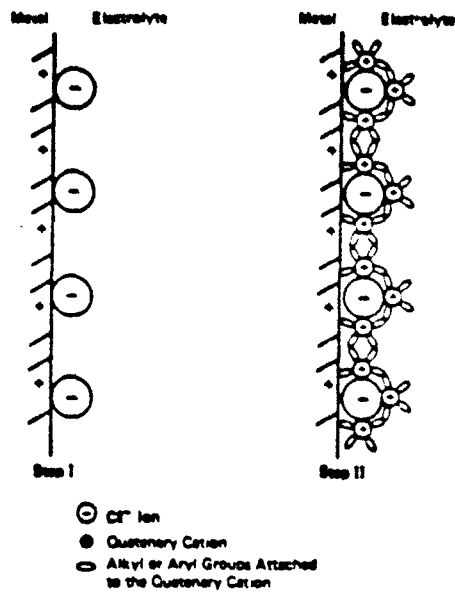

FIGURE 1 SCHEMATIC OF THE MECHANISM OF CORROSION INHIBITION OF IRON IN 0.5 M H₂SO₄ BY THE SYNERGISTIC CORROSION INHIBITOR

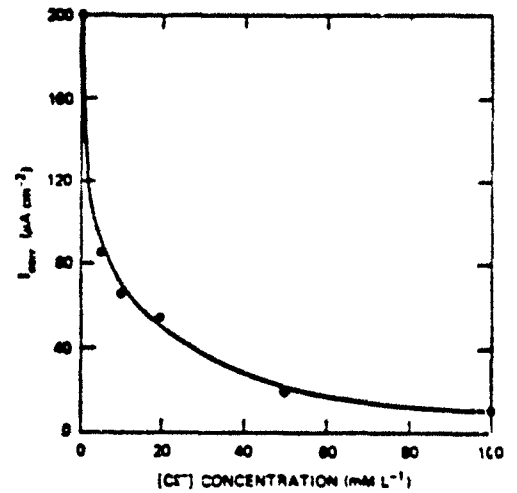

FIGURE 2 SYNERGISTIC CORROSION INHIBITION BY THE ADDED [Cl⁻] CONCENTRATION IN THE PRESENCE OF A FIXED CONCENTRATION OF INHIBITOR CATION

System: Iron in 0.5 M H₂SO₄.

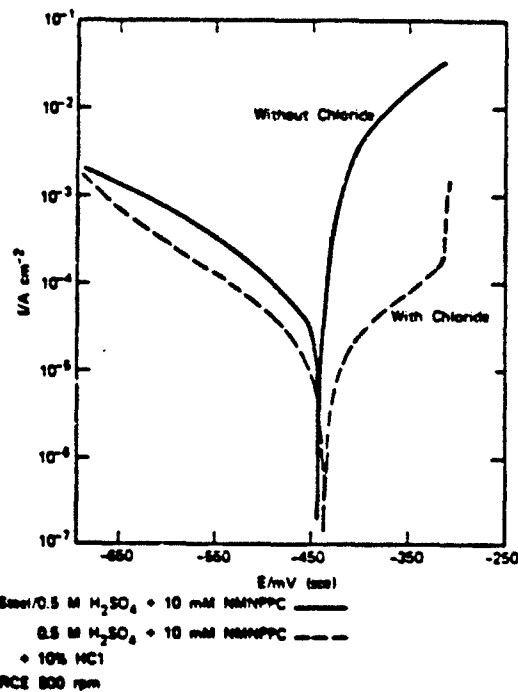
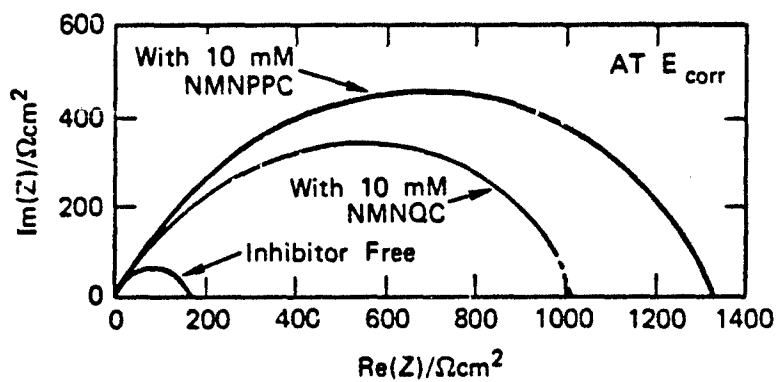

FIGURE 3 POLARIZATION CURVES FOR MILD STEEL IN 0.5 M H₂SO₄ SHOWING THE ABILITY OF THE CHLORIDE ION TO PROMOTE THE INHIBITING ACTION OF NMNPPC



RA-320583-74

FIGURE 4 THE EFFECT OF N METHYL NAPHTHYL QUINOLINIUM CHLORIDE (NMNQC) AND N₁ METHYL NAPHTHYL 4-PIPERIDINOPYRIDINIUM CHLORIDE (NMNPPC) ON THE NYQUIST PLOT FOR STEEL IN 0.5 M H₂SO₄ + 10% CONC. HCl; RCE = 500 rpm

APPENDIX

POLYMERIC DIALKYLAMINO PYRIDINES AS SUPERNUCLEOPHILIC CATALYSTS

Subhash C. Narang* and Susanna Ventura
SRI International, 333 Ravenswood Avenue
Menlo Park, California 94025

and
Rocpram Ramharack
3M Company
St. Paul, Minnesota 55144

SYNOPSIS

Supernucleophilic polymers containing the 4-(pyrrolidino)pyridine group were synthesized from the corresponding maleic anhydride copolymers and also by cyclopolymerization of N-4-pyridyl bis(methacrylimide). The resulting polymers were examined for their kinetics of quaternization with benzyl chloride and hydrolysis of *p*-nitrophenylacetate. In both instances, the polymer bound 4-(dialkylamino)pyridine was found to be a superior catalyst than the corresponding low molecular weight analog.

INTRODUCTION

4-(Dimethylamino)pyridine (1, DMAP) and its analogs, particularly 4-(pyrrolidino pyridine) (2, PPY) have acquired enormous importance utility as supernucleophilic catalysts in synthetic organic and polymer chemistry.^{1,2}

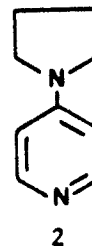
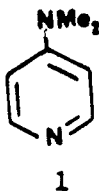

In 1967,³ it was discovered that DMAP catalyzes the benzylation of *m*-chloroaniline 10⁴ times faster than pyridine. This enormous increase in reaction rate is unmatched by any other nucleophilic acylation catalysts.³ It was shown that the catalytic action of DMAP and PPY is not primarily due to their larger pK_a with respect to pyridine, but is a result of enhanced nucleophilic catalysis.

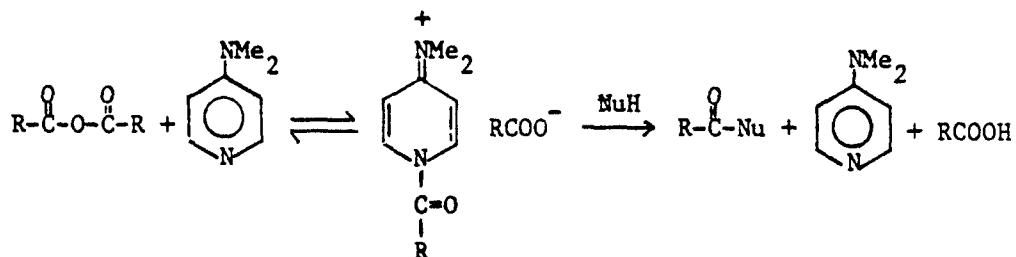

The intermediate N-acylpyridinium salt is highly stabilized by the electron donating ability of the dimethylamino group. The increased stability of the N-acylpyridinium ion has been postulated to lead to increased separation of the ion pair resulting in an easier attack by the nucleophile with general base catalysis provided by the loosely bound carboxylate anion. Dialkylaminopyridines have been shown to be excellent catalysts for acylation (of amines, alcohols, phenols, enolates), tritylation, silylation, lactonization, phosphorylation, and carbonylation and as transfer agents of cyano, arylsulfonyl, and arylsulfinyl groups. DMAP has been found to improve the coupling reaction in solid phase peptide synthesis.⁴ Polypeptides synthesized via the DMAP-DCC method were found to be of higher purity compared to other methods of synthesis. In polymer chemistry, DMAP has been used for hardening of resins and in the synthesis of polyurethanes,⁵

polycarbonates,⁶ and polyphenyleneoxides.⁷

The tremendous scope of utilization of DMAP and PPY as catalysts has led to an active interest in the development of their polymeric analogs. The pioneering work was carried out by Hierl et al.⁸ and Delaney et al.⁹ They attached 4-dialkylaminopyridine derivatives to poly(ethyleneimine) and found the modified polymers to be highly active catalysts for hydrolysis of p-nitrophenyl carboxylates. Since then, many research groups have reported the synthesis of polymers functionalized with 4-dialkylaminopyridine.¹⁰⁻¹⁸

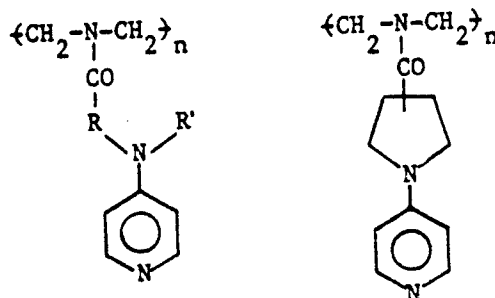

EXPERIMENTAL

Materials

All reagents and chemicals were commercially available materials purified by standard laboratory procedures. Maleic anhydride copolymers were dehydrated before use.

N-4-(Pyridyl) Methacrylamide

A solution of methacryloyl chloride (44.8 g) in tetrahydrofuran (100 ml) was added dropwise to a stirred solution of 4-aminopyridine (20 g) dissolved in a two phase system of 10% aq. NaOH (300 ml) and tetrahydrofuran (50 ml) at 15-20°C. The reaction mixture was stirred

for 2 hrs. Conc. HCl was added to the reaction mixture to lower the pH to 8 and the reaction mixture extracted with dichloromethane (4 x 100 ml). The organic extract was dried and the solvent evaporated to give the desired product in 80% yield. ^1H NMR (CDCl_3 , TMS) δ 2.05 (s), 5.6 (s), 5.9 (s), 7.8 (m), 8.6 (m), 9.6 (s).

N-4-(Pyridyl) bis(methacrylimide)

A solution of N-4-(pyridyl)methacrylamide (27 g) in tetrahydrofuran (250 ml) was added to a stirred slurry of sodium hydride (8 g) in tetrahydrofuran (150 ml) at 15-20°C under a dry nitrogen atmosphere. After stirring for 2 hrs, a solution of methacryloyl chloride (21 g) in anhydrous tetrahydrofuran (25 ml) was added dropwise over one hr and the reaction mixture stirred for another hour. The reaction mixture was quenched by addition of a few ml of methanol. The solvent was evaporated under vacuum and the crude product crystallized from ether in 60% yield, m.p. 113-114 C.

IR (KBr) 3000-2980, 1720, 1680, 1635, 1595, 1460, 1355, 1310, 1280, 1160 cm^{-1}

^1H NMR (CDCl_3 , TMS) δ 2.0 (s), 5.6 (s), 7.1 (m), 8.7 (m).

^{13}C NMR (CDCl_3) δ 18.5, 120.9, 122.5, 143.1, 146.6, 150.8, 173.3

Cyclopolymerization of N-4-(Pyridyl) bis (methacrylimide)

N-4-(Pyridyl) bis(methacrylimide) (8.6 g) was dissolved in dimethylformamide. The solution was degassed under argon and azobis(isobutyronitrile) (0.4 g) was added. The reaction mixture was heated to 75°C under argon. After 24 hrs, another portion of AIBN (0.4 g) was added and the reaction continued for another 24 hrs. The resulting polymer

was isolated by precipitation from ether in 65% yield. DSC of the polymer indicated a Tg at 110°C. TGA showed onset of decomposition at 400°C under argon. The intrinsic viscosity in chloroform was 0.05 at 30.4°C UV; λ_{\max} 230 nm (CH₂Cl₂). IR showed bands at 1790 and 1730 cm⁻¹ corresponding to the five membered imide ring.

¹H NMR (CDCl₃, TMS) δ 1.24, 1.70, 8.24, 8.67

¹³C NMR (CDCl₃) δ 15.9, 31.1, 50.7, 119.4, 139.2, 150.7, 178.8

Reduction of Poly(N-4-(pyridyl) bis(methacrylimide))

To a stirred solution of the polymer (2 g) in diglyme (100 ml), boron trifluoride etherate (1.2 ml) was added under a nitrogen atmosphere. The reaction mixture was cooled to 0°C and a slurry of sodium borohydride (1.32 g) in diglyme (80 ml) was added dropwise over 30 minutes. The reaction mixture was heated to 70°C for 16 hrs and then quenched with methanol (2-3 ml). The solvent was evaporated under vacuum and the crude product was stirred with aq. sodium hydroxide (5%, 100 ml). The polymer was filtered and the residue washed with water. The polymer was dried in a vacuum oven at 90°C. The degree of functionalization was 67% as calculated by UV and ¹H NMR spectroscopy. TGA of the pyrrolidinopyridine polymer showed the onset of weight loss at 401.8°C under argon.

UV λ_{\max} 261 nm (basic form, CH₃OH/H₂O/N₂OH)

281 nm (acidic form, CH₃OH/H₂O/HCl)

¹H NMR (d₆-DMSO, TMS) δ 0.95, 3.2, 6.4, 8.1

¹³C NMR (d₆-DMSO) δ 20, 29, 45, 59, 107, 149, 151, 152

Kinetics Experimental

The quaternization kinetics was followed by ^1H NMR spectroscopy using a JEOL FX-90Q NMR spectrometer. Solvolysis of *p*-nitrophenylacetate was followed by UV spectroscopy using a Hewlett Packard 8450 A diode array spectrophotometer.

The kinetics were followed by measuring the increase in absorbance of 400 nm due to the formation of the *p*-nitrophenoxide anion in a tris buffer solution at pH 8.5. The substrate was used in excess over the free base catalyst, whose concentration was calculated from spectrophotometric data.

Pseudo-first-order rate constants (k_{obs}) determined from the linear relationship of $\ln(A_0 - A_t)$ with time, were calculated for different concentration of catalyst. A pseudo-first-order rate constant was also calculated for the uncatalyzed hydrolysis at pH 8.5, and was subtracted from the values found for the catalyzed hydrolysis.

From the slope of the linear relationship between k_{obs} and the base concentration, the second-order-rate constants were calculated.

RESULTS AND DISCUSSION

We have previously reported a rapid two step synthesis of 4-(pyrrolidine) pyridine copolymers via the reaction of commercially available maleic anhydride copolymers with 4-aminopyridine followed by reduction with LiAlH_4 , yielding polymers with a high degree of functionalization.

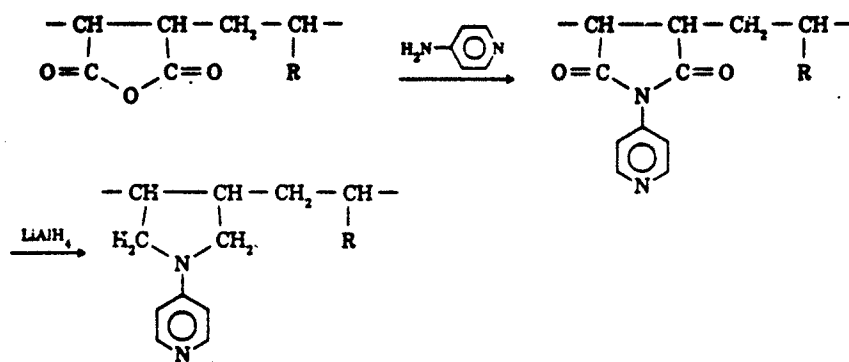

In order to determine the efficiency of the polymers as reagents in nucleophilic catalysis, it was decided to study the rate of quaternization with benzyl chloride. Table I shows the second-order rate constants for the benzylation reaction in ethanol. Comparison with DMAE indicates that poly(butadiene-co-pyrrolidinopyridine) is the most reactive of all the polymers examined and is even more reactive than the monomeric model. This enhanced reactivity is probably due to the enhanced hydrophobicity of the polymer chain in the vicinity of the reactive sites.

Table I
KINETICS OF QUATERNIZATION IN ETHANOL^a

Nucleophiline	k (mol ⁻¹ l min ⁻¹)
4-Dimethylaminopyridine	0.0010
Poly(butadiene-co-pyrrolidinopyridine)	0.0014
Poly(methyl vinyl ether-co-pyrrolidinopyridine)	0.0009
Poly(octadec-1-ene-co-pyrrolidinopyridine)	b

^aThe kinetics were studied at 25.4°C.

^bThe rate of reaction was too small to measure.

The dielectric constant of the solvent in the microenvironment of the polymer chain has been shown to be different from that in the bulk solvent. The kinetic results are consistent with the observations of Overberger et al.,¹⁹ who showed that increased hydrophobic nature of the substrate led to faster reaction rates in nucleophilic catalysis.

An alternative synthesis of supernucleophilic polymers has been achieved using the following reaction sequence.

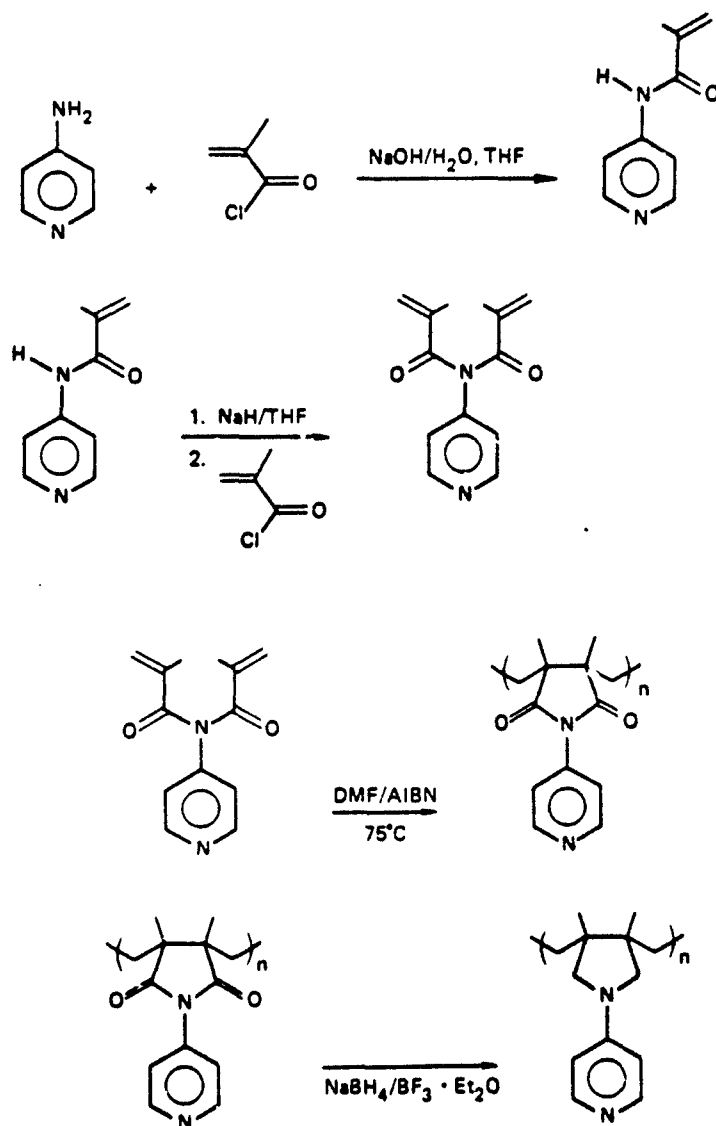

The monomer synthesis and cyclopolymerization was carried out following the procedure of Butler et al.²⁰ The resulting polyimide was shown to possess primarily pyrrolidine rings as indicated by infrared spectroscopy.²⁰ Initially, the reduction was carried out with LiAlH_4 in tetrahydrofuran. However, the reaction always led to some overreduction of the pyridine ring. Reduction with BH_3/THF was unsuccessful. However, $\text{NaBH}_4/\text{BF}_3 \cdot \text{Et}_2\text{O}$ proved to be an excellent reagent for the reduction step, resulting in the formation of the desired polymer. The polymer was shown to be 67% functionalized with primarily 4-pyrrolidinopyridine moieties, as shown by UV and NMR spectroscopy.

Kinetic Studies. The pioneering work of Hierl et al.⁸ and Delaney et al.⁹ had established that hydrolysis of *p*-nitrophenylcarboxylates was an excellent means of observing the nucleophilic catalysis by 4-(dialkylamino) pyridine functionalized polymers. Hydrolysis of *p*-nitrophenylacetate in a buffer at pH 8.5 showed that the polymer was a slightly better catalyst than the monomeric analog PPY-(Table II). However, preliminary results indicate that the polymer bound 4-(dialkylamino) pyridine is more effective as a catalyst than the monomeric analog in the hydrolysis of longer carbon chain *p*-nitrophenylcarboxylates, such as *p*-nitrophenylcoproate.

Figures I and II show a comparison of the reaction profile for PPY and polymer catalyzed hydrolysis for *p*-nitrophenylacetate and *p*-nitrophenylcoproate monitored by the appearance of *p*-nitrophenoxide absorption by UV-VIS spectroscopy. These results confirm the effectiveness of the interactions between the hydrophobic polymer chain and the hydrocarbon portion of the substrate, as it was previously mentioned, in accordance with the observations of Overberger et al.¹⁹

Table II

KINETICS OF HYDROLYSIS OF P-NITROPHENYLACETATE AT 25°C

Nucleophile	k (mol ⁻¹ l sec ⁻¹)
4-Pyrrolidinopyridine	428
Poly(4-pyrrolidinopyridine)	493

Conclusions

4-Pyrrolidinopyridine based polymers react faster with benzyl chloride than low molecular weight analogs. The polymer synthesized by cyclopolymerization of N-4-pyridyl bis(methacrylimide) followed by reduction is a supernucleophilic polymer which shows higher catalytic activity compared to the low molecular weight analogous catalyst, PPY.

Acknowledgments

We are grateful to the Army Research Office for their generous support of this work.

References

1. G. Hofle, W. Steglich and H. Vorbruggen, *Angew. Chem. Int. Ed. Engl.* **17**, 569 (1978) and references therein.
2. E.F.V. Scriven, *Chem. Soc. Rev.*, **12**, 129 (1983) and references therein.
3. (a) L. M. Litvinenko and A. I. Kirichenko, *Dokl. Akad. Nauk, SSSR Ser. Khim.*, **176**, 97 (1967).
(b) W. Steglich and G. Hofle, *Angew. Chem. Int. Ed. Engl.*, **8**, 981 (1969).
4. S. S. Wang, J. P. Tam, B.S.H. and R. B. Merrifield, *Int. J. Peptide Protein Res.*, **18**, 459 (1981).

5. J. H. Wild and F.E.G. Tate, U.S. Patent 3144 452 (1964).
6. D.B.G. Jaquiss, V. Mark, and L. C. Mitchell, U.S. Patent 4286 085 (1981).
7. J.P.L. Verlaan, P.J.T. Alferink, and G. Challa, *J. Mol. Catal.*, 24, 235 (1984).
8. M. A. Hierl, E. P. Gamson, and I. M. Klotz, *J. Am. Chem. Soc.*, 101, 6020 (1979).
9. E. J. Delaney, L. E. Wood, and I. M. Klotz, *J. Am. Chem. Soc.*, 104, 799 (1982).
10. S. Shinkai, H. Tsuji, Y. Hara, and O. Manabe, *Bull. Chem. Soc. Jpn.*, 54, 631 (1981).
11. M. Tomoi, Y. Akada, and H. Hakiuchi, *Makromol. Chem. Rapid Commun.*, 3, 537 (1982).
12. F. Guendouz, R. Jacquier, and J. Verducci, *Tetrahedron. Lett.*, 25, 4521 (1984).
13. S. C. Narang and R. Ramharack, *J. Polym. Sci. Polym. Lett. Ed.*, 23, 147 (1985).
14. L. J. Mathias, R. A. Vaidya, and R. H. Bloodworth, *J. Polym. Sci. Polym. Lett. Ed.*, 23, 289 (1985).
15. W. Storck and G. Manecke, *J. Mol. Catal.*, 30, 145 (1985).
16. F. M. Menger and D. J. McCann, *J. Org. Chem.*, 50, 3928 (1985).
17. M. Tomoi, M. Goto, H. Kaikuchi, *Makromol. Chem. Rapid Commun.*, 6, 397 (1985).
18. I. M. Klotz, S. E. Massil, and L. E. Wood, *J. Polm. Sci., Polym. Lett. Ed.*, 23, 575 (1985).
19. C. G. Overberger and A. C. Guterl, *J. Polym. Sci., Polym. Symp.*, 62, 13 (1978).
20. G. B. Butler and G. R. Myers, *J. Macromol. Sci. Chem.*, 45, 135 (1971) and references therein.

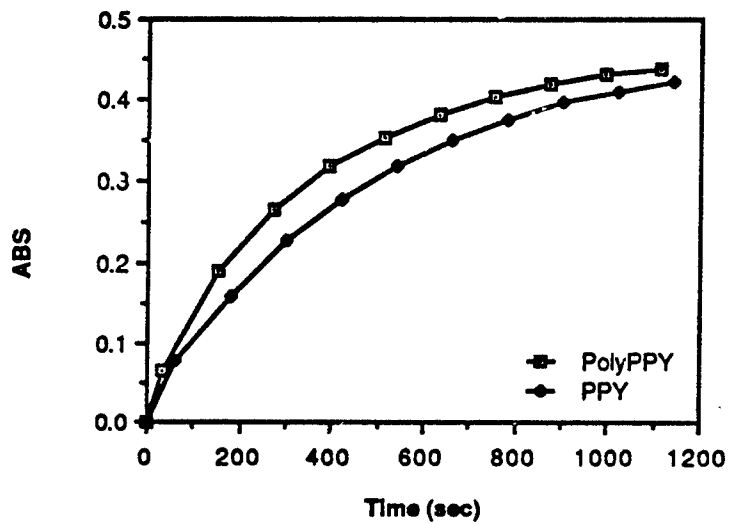

FIGURE 1. ABSORBANCE AT 400 NM VS. TIME FOR THE POLY(4-PYRROLIDINOPYRIDINE) AND 4-PYRROLIDINOPYRIDINE CATALYZED HYDROLYSIS OF p-NITROPHENYLACETATE AT pH 8.5.

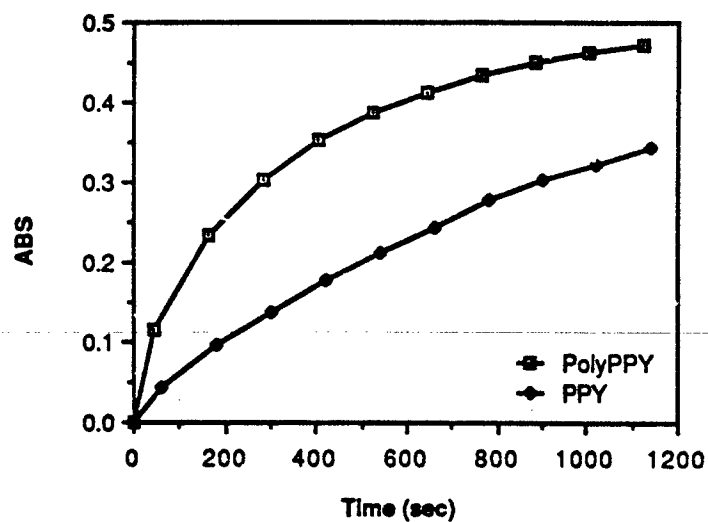

FIGURE 2. ABSORBANCE AT 400 NM VS. TIME FOR THE POLY(4-PYRROLIDINOPYRIDINE) AND 4-PYRROLIDINOPYRIDINE CATALYZED HYDROLYSIS OF *p*-NITROPHENYLACETATE AT pH 8.5