

Three-level Inverter with 60 A, 4.5 kV Si IGBT/SiC JBS Power Modules for Marine Applications

Kathleen Lentijo, IEEE Member

GE Energy Power Conversion Naval Systems, Inc
Pittsburgh, PA, USA
kathleen.lentijo@ge.com

Karl Hobart, IEEE Member

Power Electronics Branch
U.S. Naval Research Lab
Washington, DC, USA

Abstract— Semiconductor modules with medium-voltage (MV) Si IGBTs and anti-parallel silicon-carbide (SiC) junction-barrier Schottky (JBS) diodes are of interest in commercial and naval converters as they allow for significantly reduced switching losses and at present are more cost-effective than an all-SiC switch [1][2][3]. A three-level converter is being built and tested using custom modules made with 60A (120A pulsed), 4.5kV Si IGBTs and SiC JBS diodes. This work provides a platform to de-risk and evaluate the integration of SiC JBS diodes at MV using commercial modulation strategies and gating electronics with standard industry topologies for a range of switching frequencies. A comparison of SiC JBS diodes for MV, such as the decrease in turn-on IGBT losses and the elimination of snappy or avalanche recoveries is reviewed, and ways to make SiC more cost effective via topology and packaging choices are discussed.

I. INTRODUCTION

Naval power systems are demanding greater amounts of electrical power on relatively small platforms. To control and distribute such large amounts of power the move to medium-voltage (MV) power converters is essential. SiC JBS diodes are attractive at MV as they significantly reduce IGBT turn-on switching losses as compared to Si PiN diodes [4]. Additionally, Si PiN diodes may necessitate slower turn-on speeds of the IGBT, in order to prevent avalanche or snappy recovery in the diode.

Recent work has shown 6.5kV SiC diodes in a neutral-point clamped (NPC) topology significantly improves efficiency [2]. Other work with lower voltage Si IGBT/SiC JBS diodes in an NPC topology shows that the SiC JBS diodes of the complement switches can be replaced with Si diodes to reduce system cost while still maximizing the use of the SiC and achieving a high efficiency [5]. This approach is not directly applicable to the neutral-point piloted (NPP) topology since NPP does not have asymmetric switching losses in the rail devices like NPC. The NPP topology does not improve system efficiency over the NPC, but does allow for increased current throughput and potentially higher switching frequencies due to the more even distribution of

losses [6][7].

These two advantages of the NPP topology coextend benefits of SiC, and additionally, in a given application, could reduce the number of phase-legs and therefore the number of SiC devices needed; however, the NPC in some cases may benefit most from higher voltage utilization of devices that SiC JBS diodes may allow.

This work reviews SiC JBS diodes at 4.5kV as anti-parallel diodes co-packaged with Si IGBTs. The non-snappy behavior of the JBS potentially allows for higher voltage utilization of a 4.5kV IGBT/SiC JBS package versus a Si IGBT with PiN diode. An example of how higher utilization may be beneficial in the NPP and NPC topologies to reduce device count are given.

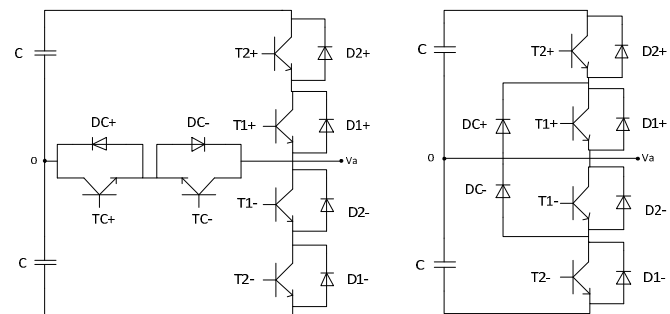

Figure 1: NPP (left) and NPC (right) topology

II. SI PiN VERSUS SiC JBS DIODE

The merits of the SiC JBS diode at MV have been evaluated versus Si PiN to demonstrate their improvement in the turn-on losses when used as the free-wheeling diode for a Si IGBT [4]. A second improvement over MV Si PiN diodes is in reducing the likelihood of snappy and avalanche recoveries during diode turn-off due to the JBS and SiC characteristics, respectively [8].

MV Si power diodes are usually PiN, which means they have an additional lightly doped intrinsic region which is required for higher blocking voltages. Low carrier lifetimes are used to ensure a rapid removal of charge and quick

Work sponsored by the Office of Naval Research and NAVSEA PMS 320 under contract N00024-12-C-4208 TI-001.

Report Documentation Page

Form Approved
OMB No. 0704-0188

Public reporting burden for the collection of information is estimated to average 1 hour per response, including the time for reviewing instructions, searching existing data sources, gathering and maintaining the data needed, and completing and reviewing the collection of information. Send comments regarding this burden estimate or any other aspect of this collection of information, including suggestions for reducing this burden, to Washington Headquarters Services, Directorate for Information Operations and Reports, 1215 Jefferson Davis Highway, Suite 1204, Arlington VA 22202-4302. Respondents should be aware that notwithstanding any other provision of law, no person shall be subject to a penalty for failing to comply with a collection of information if it does not display a currently valid OMB control number.

1. REPORT DATE APR 2013	2. REPORT TYPE N/A	3. DATES COVERED -	
4. TITLE AND SUBTITLE Three-level Inverter with 60 A, 4.5 kV Si IGBT/SiC JBS Power Modules for Marine Applications		5a. CONTRACT NUMBER	
		5b. GRANT NUMBER	
		5c. PROGRAM ELEMENT NUMBER	
6. AUTHOR(S)		5d. PROJECT NUMBER	
		5e. TASK NUMBER	
		5f. WORK UNIT NUMBER	
7. PERFORMING ORGANIZATION NAME(S) AND ADDRESS(ES) IEEE Member GE Energy Power Conversion Naval Systems, Inc Pittsburgh, PA, USA		8. PERFORMING ORGANIZATION REPORT NUMBER	
9. SPONSORING/MONITORING AGENCY NAME(S) AND ADDRESS(ES)		10. SPONSOR/MONITOR'S ACRONYM(S)	
		11. SPONSOR/MONITOR'S REPORT NUMBER(S)	
12. DISTRIBUTION/AVAILABILITY STATEMENT Approved for public release, distribution unlimited			
13. SUPPLEMENTARY NOTES See also ADA581781. IEEE Electric Ship Technologies Symposium (IEEE ESTS 2013) Held in Arlington, Virginia on April 22-24, 2013. U.S. Government or Federal Purpose Rights License.			
14. ABSTRACT Semiconductor modules with medium-voltage (MV) Si IGBTs and anti-parallel silicon-carbide (SiC) junction-barrier Schottky (JBS) diodes are of interest in commercial and naval converters as they allow for significantly reduced switching losses and at present are more cost-effective than an all-SiC switch [1][2][3]. A three-level converter is being built and tested using custom modules made with 60A (120A pulsed), 4.5kV Si IGBTs and SiC JBS diodes. This work provides a platform to de-risk and evaluate the integration of SiC JBS diodes at MV using commercial modulation strategies and gating electronics with standard industry topologies for a range of switching frequencies. A comparison of SiC JBS diodes for MV, such as the decrease in turn-on IGBT losses and the elimination of snappy or avalanche recoveries is reviewed, and ways to make SiC more cost effective via topology and packaging choices are discussed.			
15. SUBJECT TERMS			
16. SECURITY CLASSIFICATION OF:			17. LIMITATION OF ABSTRACT
a. REPORT unclassified	b. ABSTRACT unclassified	c. THIS PAGE unclassified	SAR
			18. NUMBER OF PAGES 4
			19a. NAME OF RESPONSIBLE PERSON

recovery times; however, this can lead to the space charge region occupying the whole drift region before the reverse-recovery current is zero, which causes the reverse-recovery current to snap to zero and cause damaging overvoltages on the diode due to the high di/dt [9]. The effect is particularly exacerbated at low forward currents.

As described in [8], a damping factor can be defined for the PiN diode during turn-off such that values greater than one for the damping factor, ζ , indicate a soft recovery, and a damping factor less than 1 and approaching zero indicate the possibility of a snappier recovery. The damping factor is defined below.

$$\zeta = \frac{C_T + g_D \cdot L_C}{2\sqrt{L_C \cdot C_T(1 + g_D)}}$$

Where g_D is the conductance of the diode, C_T is the capacitance across the diode, and L_C is the commutation inductance. From the parameters that define the damping factor, the most easily influenced by a converter design perspective is the commutation inductance. From the damping factor it can be shown that larger values of commutation inductance, L_C lead to a softer recovery as shown in Figure 2 for generic constant values of g_D and C_T .

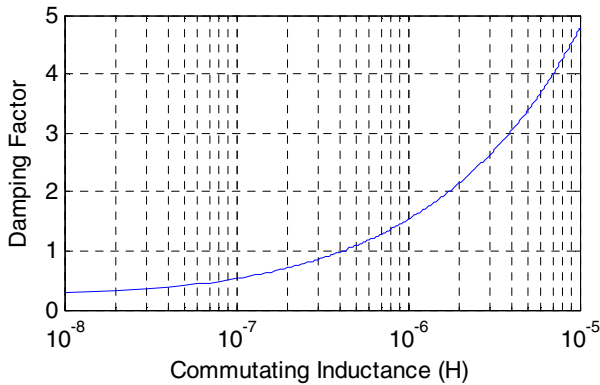

Figure 2: Example of increased damping with increasing commutation inductance

Increasing commutation inductance may ensure a softer recovery; however, it has several implications. First, it can slow down the turn-on and turn-off of both the IGBT and diode which can lead to larger switching loss. Secondly, it increases the overshoot of V_{ce} during the IGBT turn-off as shown in the equation below.

$$V_{CE_peak} = V_{CE_steadystate} - L_C \cdot \frac{di}{dt}$$

Should the V_{CE_peak} reach dangerous levels due to the additional inductance, overvoltage snubbers, such as parallel resistive-capacitive circuits, may be sized to limit the V_{CE} overshoot at IGBT turn-off and the diode overvoltage at diode turn-off. Regardless, the device may need to be switched at only a portion of its nominal rating to confirm the avoidance of damaging overvoltages; therefore, the snappiness can drive system level design decisions such as

the amount of commutation inductance, snubber size, or a voltage derating of the semiconductor devices.

Example results for a 1.5kA, 4.5kV IGBT and Si PiN FWD without any form of snubber are shown below for a commutation inductance of approximately 300nH during turn-off at different levels of current.

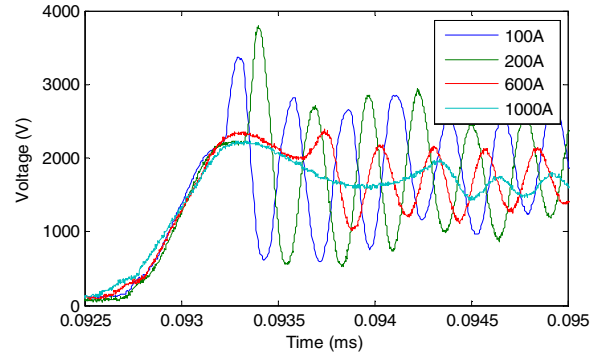

Figure 3: 4.5kV Si PiN Diode turnoff with approximately 300nH commutation in inductance at varying current

This result is compared with the 60A, 4.5kV SiC JBS diode package in a set-up with a commutation inductance of 1.4uH. Likewise there is no snubber used. The result is shown below in Figure 4.

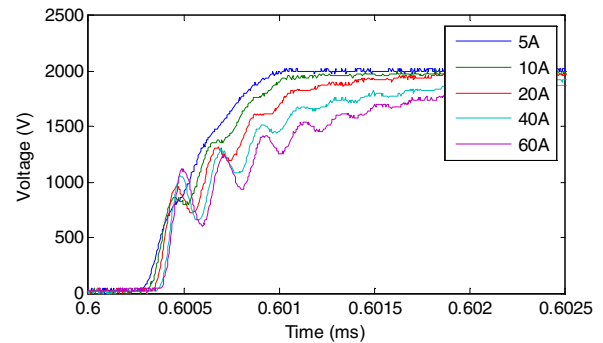

Figure 4: 4.5kV Si PiN Diode turnoff with 1.4uH commutation in inductance at varying current

Due to the JBS there is no additional intrinsic region and therefore the turn-off exhibits no snappy behavior although there is a considerable oscillation in the diode voltage and reverse recovery current (not shown). Another example of the same JBS SiC diode at 2kV with significantly less commutation inductance is shown in Figure 5, where the commutation inductance is reduced to around 300nH.

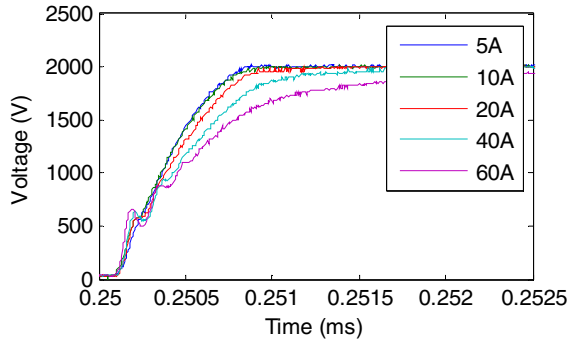

Figure 5: 4.5kV Si PiN Diode turnoff with approximately 300nH commutation in inductance at varying current

Finally, with the low commutation inductance of 300nH, it is shown in Figure 6 that at 3kV there is still almost negligible voltage overshoot.

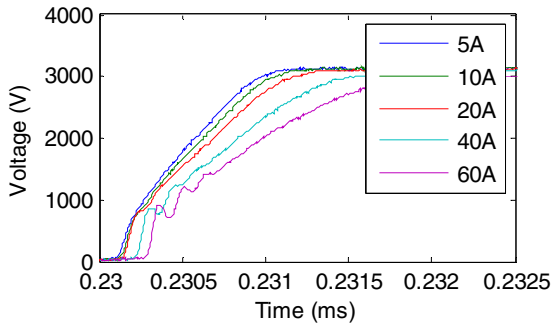

Figure 6: 4.5kV Si PiN Diode turnoff at 3kV with 300nH commutation in inductance at varying current

While this test set-up was limited, it is likely that with a low commutation inductance the switch can operate over 3kV.

III. REDUCING SiC DEVICE COUNT

While the benefits of SiC may be apparent, the semiconductor is at present more expensive than Si; therefore, topologies and die ratios that reduce the cost, but still exploit the benefits of the SiC JBS diodes are of interest for commercial applications. While Si semiconductor devices do not make up an overwhelming percentage of the cost of a commercial drive, the introduction of SiC to increase efficiency or switching frequency can quickly make the converter less cost competitive. One way to reduce this cost is to still exploit the benefits of the SiC, but reduce the number of SiC devices.

As mentioned before, the NPP topology allows for better current utilization of the semiconductor devices than the NPC as the losses are more evenly distributed. This loss distribution is demonstrated in a thermal simulation with the 4.5kV devices in an NPP versus an NPC configuration in Figure 7. The NPP topology on the left has the same loss on T1+ and T2+ in Figure 1, while for the NPC, T2+ has significantly more loss than T1+. As a result the phase-leg is limited by the temperature of T2+ and cannot go as high in

current or switching frequency as the NPC for the same operating conditions.

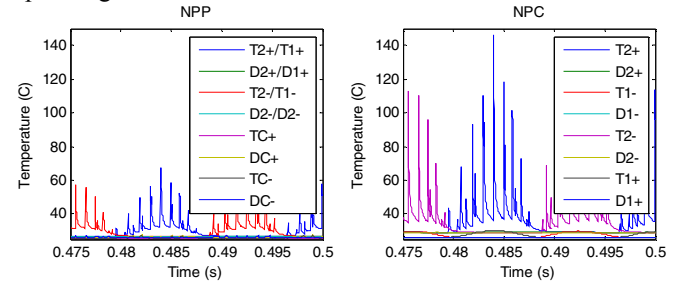

Figure 7: Thermal simulation of NPP (left) and NPC (right) for the same operating conditions.

made up of the comparable number of devices, the NPP will have a higher overall wattage rating than the NPC and therefore may allow less phase-legs, and less SiC devices, per an application.

Another interesting point of comparison is the voltage utilization of the devices in the NPP and NPC. The main difference between the two topologies in this case is that the rail devices must switch and block $V_{dc}/2$ in the case of the NPC. In the case of the NPP they must block $V_{dc}/2$ but must only switch at $V_{dc}/4$ (assuming two series devices).

An analysis is done below in Table 1 for a DC link voltage at 7kV, i.e. nominally a 4160V AC interface, and assuming the 4.5kV IGBT/SiC JBS diode devices. At a 1.8kV allowable device switching voltage, the NPP clearly has an advantage in terms of device count; however, while a higher switching voltage is advantageous for both the NPP and NPC topology as shown in Table 1, a 4.5kV rated (or higher) device capable of switching at 3.5kV allows for the same number of SiC JBS diodes as the NPP and 6 less IGBTs per a three-phase converter. This coupled with the fact that series device matching or voltage sharing snubbers may not be needed for the NPC make the NPC with devices capable of switching at 3.5kV devices an attractive solution for a 4160V interfaced converter.

Table 1: Device Count for NPP and NPC per 3-phase Converter, $V_{dc} = 7kV$, at 1.8 kV versus 3.5 kV switching

Switch Group	NPC				NPP			
	Block	Switch	# per SG		Block	Switch	# per SG	
			1.8kV	3.5 kV			1.8kV	3.5 kV
T2/D2	3.5 kV	3.5 kV	2	1	3.5 kV	1.75kV	1	1
T1/D1	3.5 kV	3.5 kV	2	1	3.5 kV	1.75kV	1	1
TC/DC*	3.5 kV	3.5 kV	2*	1*	3.5 kV	3.5 kV	2	1
# per rail			6	3			4	3
Total			36	18			24	18

*For NPC there is no complement transistor (TC)

The results of Table 1 are particular to the DC link, switching, and blocking voltages; however, the analysis demonstrates the advantage of device voltage utilization.

IV. CONCLUSION

The 4.5 kV SiC JBS diode co-packaged with a Si IGBT has potential to provide improved performance for medium-voltage three-level voltage source converters. The possibility of improved voltage utilization due to the non-snappy recovery in particular can help bring down the cost of use of the SiC modules.

ACKNOWLEDGMENT

This work was made possible by the Office of Naval Research and the Naval Research Laboratory, the National Institute of Standards and Technology, and NAVSEA PMS 320.

REFERENCES

- [1] F. Kub, "Silicon Carbide Power Device Status and Issue," *Energytech, 2012 IEEE*, 29-31 May 2012H.
- [2] Mirzaee, S. Bhattacharya, S. H. Ryu, A. Agarwal, "Design Comparison of 6.5kV Si-IGBT, 6.5kV SiC JBS Diode, and 10kV SiC MOSFETs in Megawatt Converters for Shipboard Power System," in Proc. *Electric Ship Technologies Symposium*, Alexandria, USA, April 2011, pp. 248-253.
- [3] <http://www.pwr.com/summary/SiC-Modules.aspx?c=55>
- [4] T. Duong, A. Hefner, K. Hobart, S. Ryu, D. Grider, D. Berning, J. Ortiz-Rodriguez, E. Imhoff, and J. Sherbondy, "Comparison of 4.5 kV SiC JBS and Si PiN diodes for 4.5 kV Si IGBT anti-parallel diode applications," in *Applied Power Electronics Conference and Exposition (APEC), 2011 Twenty-Sixth Annual IEEE*, March 2011, pp. 1057-1063.
- [5] M. Schweizer, T. Friedli, and J. W. Kolar, "Comparison and implementation of a 3-level NPC voltage link back-to-back converter with SiC and Si diodes," in *Proc. 25th IEEE Appl. Power Electron. Conf.*, Palm Springs, CA, Feb. 2010, pp. 1527-1533.
- [6] V. Guennegues, B. Gollentz, F. Meibody-Tabar, S. Rael, and L. Leclere, "A converter topology for high speed motor drive applications," in *Proc. 13th EPE*, Oct. 2009, p. 8
- [7] Kouro, S.; Malinowski, M.; Gopakumar, K.; Pou, J.; Franquelo, L.G.; Bin Wu; Rodriguez, J.; Pérez, M.A.; Leon, J.L.; "Recent Advances and Industrial Applications of Multilevel Converters," *Industrial Electronics, IEEE Transactions on* , vol.57, no.8, pp.2553-2580, Aug. 2010.
- [8] M.T. Rahimo and N.Y.A. Shammass, "Freewheeling diode reverse recovery failure modes in IGBT applications," in *IEEE Trans. Industry Applications*, 37(2):661-670, March/April 2001.
- [9] Bryant, A.T.; Palmer, P.R.; Santi, E.; Hudgins, J.L.; , "A Compact Diode Model for the Simulation of Fast Power Diodes including the Effects of Avalanche and Carrier Lifetime Zoning," *Power Electronics Specialists Conference, 2005. PESC '05. IEEE 36th* , vol., no., pp.2042-2048, 16-16 June 2005.