

# DESIGN OF A HYDROGEN MASER FOR SPACE

E.M. Mattison and R.F.C. Vessot  
Smithsonian Astrophysical Observatory  
Cambridge, Massachusetts 02130, USA

## Abstract

*An active atomic hydrogen maser for long-term use in space has been designed and built as part of the Smithsonian Astrophysical Observatory's Hydrogen Maser Clock (HMC) project. We describe features of the maser's mechanical, magnetic, and thermal design that are important to its performance in space. The flight hardware has been tested in a laboratory vacuum chamber. We report measurements of the performance of the maser's control systems.*

## CLOCKS IN SPACE: THE HYDROGEN MASER CLOCK PROGRAM

Frequency references – high stability clocks – increasingly find applications in space missions. Atomic clocks of ever increasing stability have present and potential uses as frequency references for the GLONASS and Global Positioning System navigation systems, local oscillators for space-based Very Long Baseline Interferometry, “proper” clocks for tests of general relativity, frequency references for detection of gravitational radiation, and “traveling clocks” for worldwide time transfer.

Clocks for use in space must satisfy several restrictions and requirements, many of which are also requirements or desirable features of earth-based clocks. These requirements include:

- Limitations on mass, size and power
- Requirements for reliable long-term unattended operation
- Ability to withstand vibrational loads during launch
- Ability to tolerate varying magnetic fields
- Ability to cope with a varying thermal environment.

An active atomic hydrogen maser for long-term use in space has been designed and built as part of the Smithsonian Astrophysical Observatory's Hydrogen Maser Clock (HMC) project. HMC is a NASA-sponsored program with the goal of producing and demonstrating a space-qualified hydrogen maser with drift-removed fractional frequency stability of  $10^{-15}$  or better in one day. The HMC maser is an evolutionary outgrowth of a two-decade long SAO program of research and development of hydrogen masers for earth and space use.<sup>[1,2,3]</sup> The maser and its control electronics have been designed as an integrated system to cope with the requirements of space flight. We discuss below characteristics of its mechanical, magnetic, and thermal design that are particularly relevant to use in space.

# Report Documentation Page

*Form Approved*  
*OMB No. 0704-0188*

Public reporting burden for the collection of information is estimated to average 1 hour per response, including the time for reviewing instructions, searching existing data sources, gathering and maintaining the data needed, and completing and reviewing the collection of information. Send comments regarding this burden estimate or any other aspect of this collection of information, including suggestions for reducing this burden, to Washington Headquarters Services, Directorate for Information Operations and Reports, 1215 Jefferson Davis Highway, Suite 1204, Arlington VA 22202-4302. Respondents should be aware that notwithstanding any other provision of law, no person shall be subject to a penalty for failing to comply with a collection of information if it does not display a currently valid OMB control number.

1. REPORT DATE <b>DEC 1996</b>	2. REPORT TYPE	3. DATES COVERED <b>00-00-1996 to 00-00-1996</b>			
4. TITLE AND SUBTITLE <b>Design of a Hydrogen Maser for Space</b>		5a. CONTRACT NUMBER			
		5b. GRANT NUMBER			
		5c. PROGRAM ELEMENT NUMBER			
6. AUTHOR(S)		5d. PROJECT NUMBER			
		5e. TASK NUMBER			
		5f. WORK UNIT NUMBER			
7. PERFORMING ORGANIZATION NAME(S) AND ADDRESS(ES) <b>Smithsonian Astrophysical Observatory, Cambridge, MA, 02130</b>		8. PERFORMING ORGANIZATION REPORT NUMBER			
9. SPONSORING/MONITORING AGENCY NAME(S) AND ADDRESS(ES)		10. SPONSOR/MONITOR'S ACRONYM(S)			
		11. SPONSOR/MONITOR'S REPORT NUMBER(S)			
12. DISTRIBUTION/AVAILABILITY STATEMENT <b>Approved for public release; distribution unlimited</b>					
13. SUPPLEMENTARY NOTES <b>See also ADA419480. 28th Annual Precise Time and Time Interval (PTTI) Applications and Planning Meeting, Reston, VA, 3-5 Dec 1996</b>					
14. ABSTRACT <b>see report</b>					
15. SUBJECT TERMS					
16. SECURITY CLASSIFICATION OF:			17. LIMITATION OF ABSTRACT <b>Same as Report (SAR)</b>	18. NUMBER OF PAGES <b>7</b>	19a. NAME OF RESPONSIBLE PERSON
a. REPORT <b>unclassified</b>	b. ABSTRACT <b>unclassified</b>	c. THIS PAGE <b>unclassified</b>			

The HMC maser is designed for use with a variety of spacecraft, requiring only an appropriate mechanical connection and electrical interface. It was originally to be tested aboard the European Space Agency's Eureka spacecraft, and then, following cancellation of the planned Eureka reflight, on the Russian Mir space station.<sup>[4]</sup> At present, the flight portion of the HMC program has been terminated, and the flight model maser and its electronics are undergoing laboratory testing at SAO.

## MECHANICAL AND STRUCTURAL CHARACTERISTICS

The HMC maser's physics unit, shown in cross-section in Figures 1 and 2, takes the general form of a cylinder 84 cm long and 43 cm in diameter. The maser's main components are its quartz storage bulb and low-expansion resonant cavity; the titanium vacuum tank that contains the cavity; a stainless steel vacuum manifold that includes two sorption pumps for scavenging hydrogen and two small ion pumps for removing other gases; a  $\text{LiAlH}_4$  hydrogen source and a glass dissociator chamber for producing a beam of hydrogen atoms; electrical heaters, insulation, and thermistors for temperature control; and magnetic shields and solenoids for magnetic field control. In addition, the physics unit contains electronic components that amplify the 1,420 MHz maser signal from the cavity and electrically isolate the cavity from external perturbations. Separate units contain analog and digital control and monitoring electronics, the RF receiver that phase-locks a 100 MHz crystal oscillator to the maser signal, and a microprocessor that controls the maser's electronics and acts as an interface with the spacecraft's data and telecommand system. The masses of the major instrument elements are given in Table 1. Additional elements, whose masses depend upon the specific spacecraft used, are the bracket that mounts the maser to the spacecraft, and any additional spacecraft-specific electronics.

Table 1. HMC Instrument Mass Summary

Element	Mass (kg)
Maser physics unit	70.7
Control and RF electronics	27.9

Structurally, the maser is supported from a circular aluminum midplane plate, which supports the maser's resonant cavity and vacuum tank on one side, and its vacuum manifold and hydrogen source on the other. The midplane plate is the main structure for mounting the maser to the spacecraft. A titanium "aft neck" tube connects one end of the vacuum tank to the midplane plate and the vacuum manifold, while a similar "forward neck" connects the other end of the vacuum tank to the maser's cylindrical outer aluminum housing. The housing, in turn, transfers the forward neck's load to the midplane plate. By means of an ANSYS finite element model with approximately 2,800 nodes, the HMC maser has been designed to cope with the vibrational and accelerational loads of a Space Shuttle launch. It can withstand at least 15 g's rms, in all axes acting simultaneously, in a spectrum from 20 Hz to 2 kHz. The maser's lowest mechanical resonant frequency is 46 Hz. The flight cavity and vacuum tank, which are the most critical components, have been tested to flight input vibrational levels.

## MAGNETIC FIELD CONTROL

A spacecraft in low earth orbit experiences the earth's magnetic field, with a magnitude of about 0.5 gauss and a variation over an orbit of up to  $\pm 0.5$  gauss, depending upon the spacecraft's attitude in orbit. In addition, some spacecraft create variable magnetic fields themselves, for example by magnetic torquers used for attitude control. The magnetic field within the maser's

storage bulb must be maintained at a level on the order of 0.3 milligauss. To achieve frequency stability of better than  $\Delta f/f < 1 \times 10^{-15}$ , the temporal variation of the internal magnetic field must be less than  $\Delta H < 0.8 \times 10^{-6}$  gauss. To achieve these conditions, the HMC maser utilizes passive magnetic shields, internal solenoids, and an active magnetic compensation system.

As shown in Figure 1, the maser's resonant cavity and titanium vacuum tank are surrounded by a three-section, two-layer cylindrical printed circuit solenoid that creates the internal magnetic field of approximately 0.3 milligauss, and by four layers of concentric magnetic shields that attenuate external fields. The outermost shield extends to enclose the vacuum pump manifold and atomic hydrogen dissociator, reducing external fields that could perturb the state-selected atomic hydrogen beam. The measured shielding factor of these Hypernom shields is

$$S_{\text{passive}} = \frac{\Delta H_{\text{ext}}}{\Delta H_{\text{int}}} \approx 3.4 \times 10^5$$

The passive shields are augmented by an active magnetic compensation system. A single-axis fluxgate magnetometer sensor is mounted inside the outer shield to sense the axial field near the end of the maser. A compensation coil is wound on the outside cylindrical surface of the next shield, and a feedback circuit drives the coil to keep the field sensed by the magnetometer constant. The shielding factor for the total magnetic control system, determined by measuring the transverse ("Zeeman") resonance frequency in the oscillating maser's storage bulb, is

$$S_{\text{total}} \approx 2.8 \times 10^6$$

With this shielding factor, the expected maximum fractional frequency variation due to movement through the earth's field is on the order of  $\Delta f/f \sim 2 \times 10^{-16}$ .

## THERMAL CONTROL SYSTEM DESIGN FEATURES

Temperature changes of the maser's resonant cavity and storage bulb affect the maser's output frequency. To keep frequency variations below the level of 1 part in  $10^{15}$ , the cavity temperature must be maintained constant to approximately  $10^{-4}$  °C. The HMC maser employs several strategies to achieve this level of temperature control. To control heat flow from the vacuum tank, the maser's structure is divided into three concentric isothermal control regions. Thermal gradients are controlled by subdividing each isothermal region into multiple independently controlled zones, by mounting controlled guard heaters on heat leakage paths, by separating heaters from the primary controlled structure (the vacuum tank), and by carefully calibrating and matching thermistors and setpoint resistors to ensure that all zones of an isothermal region control at the same temperature. Radiative heat flow is reduced by means of multilayer insulation in the spaces between the regions, which are evacuated by being open to the space environment, while conductive heat flow is controlled by design of the segmented nylon rings that support the magnetic shields.

As shown in Figure 2, the innermost isothermal region, which is the titanium vacuum tank that surrounds the resonant cavity, is maintained at 50°C. The resolution of the tank control system is  $1 \times 10^{-4}$  degrees. To reduce thermal gradients in the tank, the three tank heaters are separate from the tank itself, one being located on the outside surface of the inner magnetic shield that is directly outside the tank and the others on the titanium neck tubes where they connect to either end of the tank.

The tank, in turn, is surrounded by an aluminum oven that is located directly over the third magnetic shield and whose temperature is maintained at 41°C. The oven region acts as a guard to control heat that flows from the tank region both radiatively from the tank surface and conductively along the magnetic shield supports and the titanium support necks. The oven region consists of three control zones located on the cylinder and end surfaces of the oven, and two zones mounted on the outer ends of the support necks.

The third isothermal region consists of the midplane plate and an outer aluminum support shell that directly surrounds the fourth magnetic shield. This zone is maintained at approximately 27°C by a control thermistor and a set of heaters mounted on the midplane plate.

In addition to the thermal control zones that are integral with the maser, the system includes a controlled temperature guard station on the structure that mounts the maser to the spacecraft, to act as a first stage of isolation from the conductive environment. The entire instrument is surrounded with multilayer insulation to isolate it from the radiative environment.

The thermal control system incorporates several electronic and hardware features to achieve the high degree of thermal stability required. The digital electronic control system is based upon four 68HC11 microcontrollers, each of which can control up to five thermal zones. Each 68HC11 includes a microprocessor, an 8-bit analog-to-digital converter with an eight-channel multiplexer, and timer registers that are used as pulse-width modulators (PWM) for high-efficiency switched heater power control. The vacuum tank heaters, which are closest to the maser's resonant cavity, are powered by high-frequency (~8 kHz) PWMs to avoid perturbation of the maser oscillation; the other heaters are switched at a 30 Hz rate. The thermal control program incorporates a three-mode PID (proportional, integral, and differential) algorithm to eliminate proportional offset. (Differential control is included in the algorithm, but has not been found to be useful in this application.)

Components of the thermal control system have been chosen for thermal stability and low magnetic field production. Thermistors are glass-encapsulated, high-stability units that have been burned in. Monitor and control thermistors for each zone are chosen to be matched. Temperature setpoint resistors are chosen to have low temperature coefficients, and are physically mounted on a temperature-controlled zone within the maser for minimum temperature perturbation. Heaters are flexible printed circuits with Kapton film insulation. For each heater, identical etched foil elements are overlaid with opposite current flow, to minimize magnetic field production.

The ability of the thermal control system to stabilize the tank zone temperatures in the face of external temperature changes is shown by the data of Table 2. For these measurements, which were made on the engineering model of the maser, the temperatures of the maser support structure and the forward neck guard zone were separately lowered by 2°C.

Table 2. Response of Tank Control Zones to External Temperature Change

	$\Delta T$ (Support) = $-2^{\circ}\text{C}$	$\Delta T$ (Fwd neck) = $-2^{\circ}\text{C}$
$\Delta T$ (Tank forward):	$-0.1 \times 10^{-4} \text{ }^{\circ}\text{C}$	$+0.2 \times 10^{-4} \text{ }^{\circ}\text{C}$
$\Delta T$ (Tank cylinder):	$+1 \times 10^{-4} \text{ }^{\circ}\text{C}$	$-1 \times 10^{-4} \text{ }^{\circ}\text{C}$
$\Delta T$ (Tank aft):	$+3 \times 10^{-4} \text{ }^{\circ}\text{C}$	$-2 \times 10^{-4} \text{ }^{\circ}\text{C}$

## REFERENCES

- [1] M.W. Levine, R.F.C. Vessot, E.M. Mattison, E. Blomberg, T.E. Hoffman, G. Nystrom, D.F. Graveline, R.L. Nicoll, C. Dovidio, and W. Brymer 1977, "A hydrogen maser design for ground applications," Proceedings of the 8th Annual Precise Time and Time Interval (PTTI) Applications and Planning Meeting, 30 November-2 December 1976, Washington, D.C., USA, pp. 249-276.  
M.W. Levine, R.F.C. Vessot, E.M. Mattison, G. Nystrom, T.E. Hoffman, and E. Blomberg 1977, "A new generation of SAO hydrogen masers," Proceedings of the 31st Annual Symposium on Frequency Control, 1-3 June 1977, Atlantic City, New Jersey, USA (U.S. Army Electronics Command), pp. 525-534.
- [2] R.F.C. Vessot, M.W. Levine, E.M. Mattison, E.L. Blomberg, T.E. Hoffman, G.U. Nystrom, B.F. Farrell, R. Decher, P.B. Eby, C.R. Baugher, J.W. Watts, D.L. Teubr, and F.D. Wills 1980, "Test of relativistic gravitation with a space-borne hydrogen maser," *Physical Review Letters*, **45**, 2081.
- [3] E. M. Mattison 1989, "Ultra-stable clocks for use in space," *Advances in Space Research*, **9**, (9)13-(9)19.
- [4] E.M. Mattison, and R.F.C. Vessot 1996, "High precision time transfer to test a hydrogen maser on Mir," Proceedings of the 27th Annual Precise Time and Time Interval (PTTI) Applications and Planning Meeting, 29 November-1 December 1995, San Diego, California, USA (NASA CP-3334), pp. 181-192.

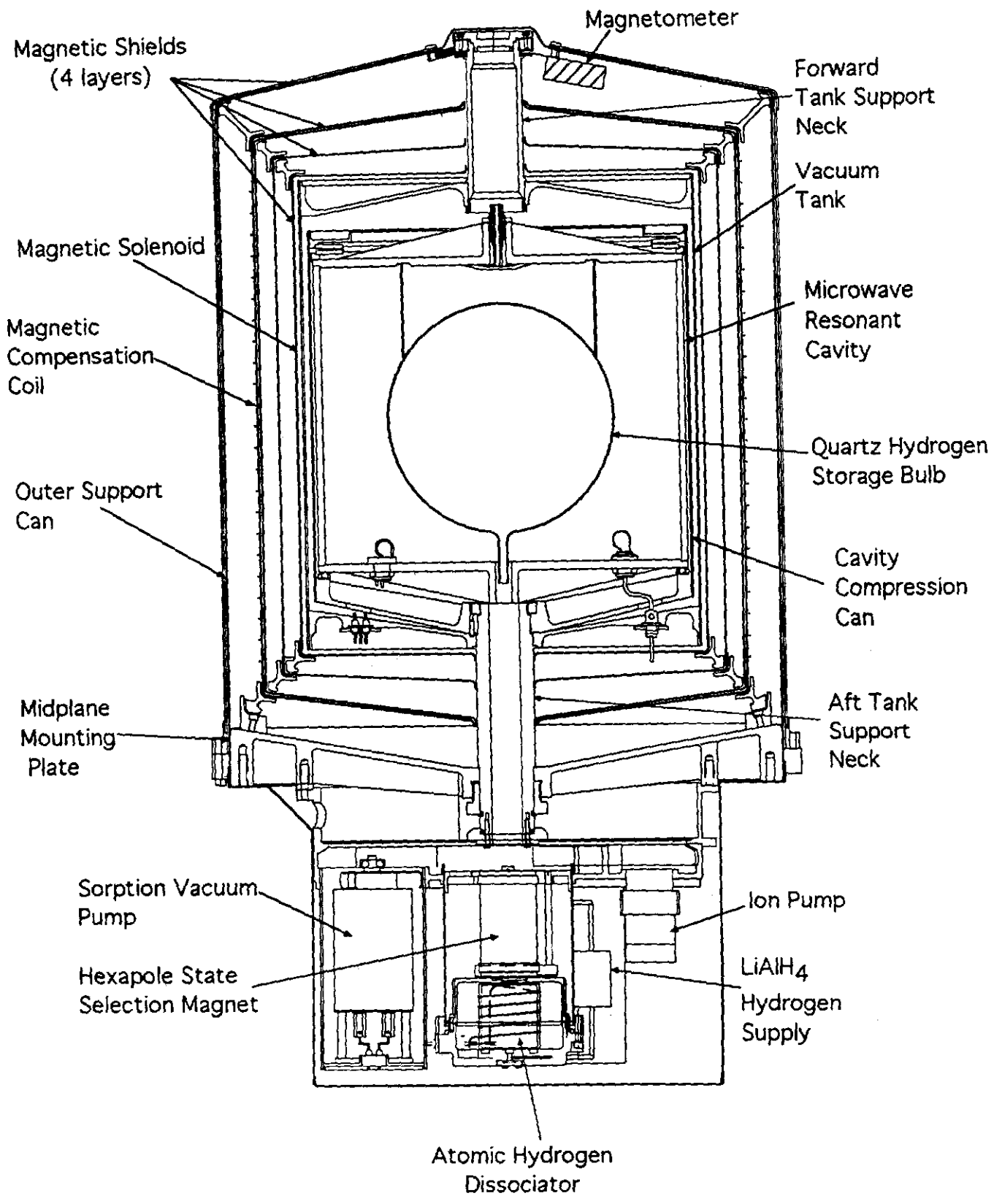

Figure 1. HMC maser - major components

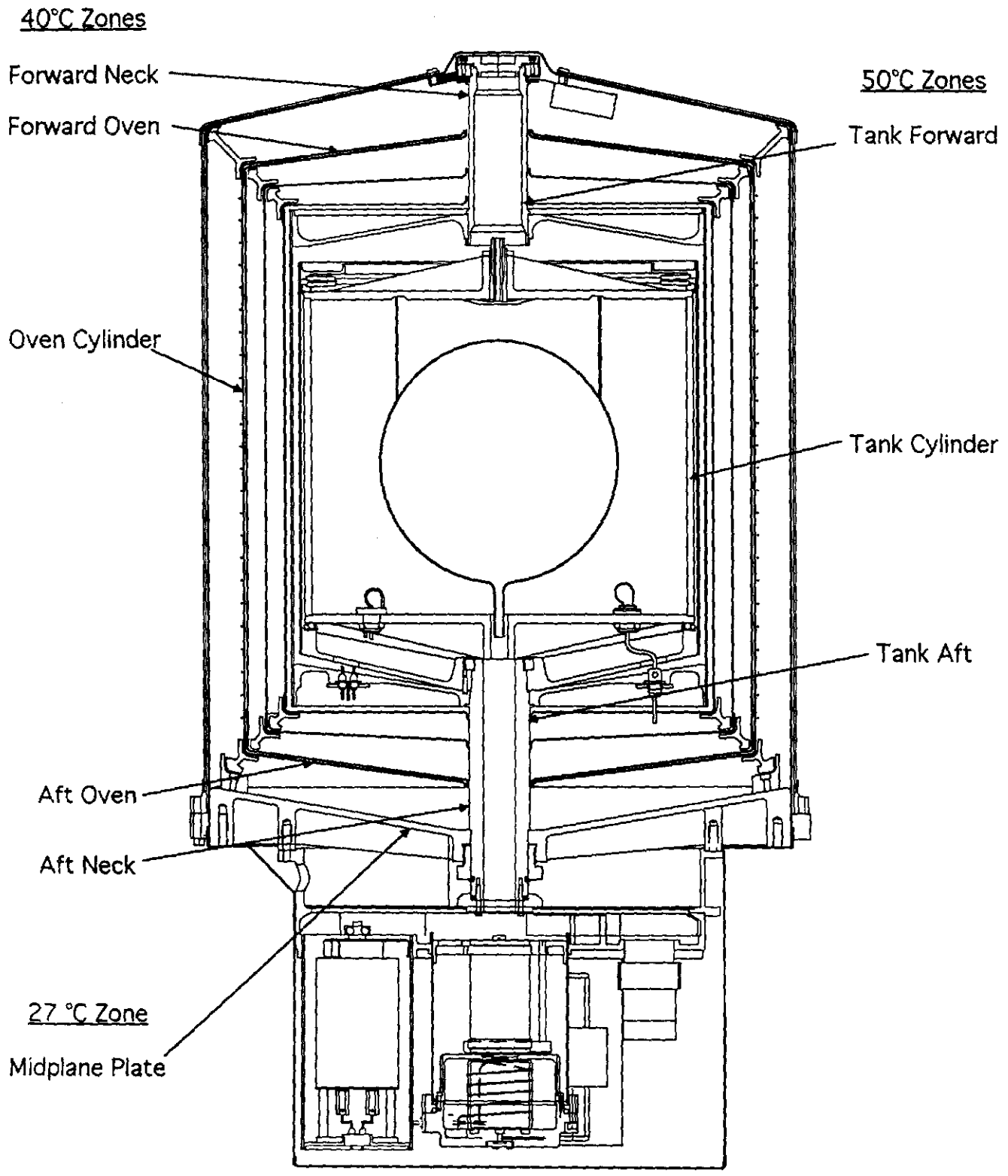

Figure 2. Thermal Control Zone Locations