



# Aircraft Transparency Testing - Artificial Birds

C. J. Welsh  
Calspan Corporation  
and  
1st Lt Vincent Centonze, USAF

PROPERTY OF U.S. AIR FORCE  
AEDC TECHNICAL LIBRARY

April 1986

Final Report for Period July 1, 1984 – May 1, 1985

**TECHNICAL REPORTS  
FILE COPY**

Approved for public release; distribution unlimited.

**ARNOLD ENGINEERING DEVELOPMENT CENTER  
ARNOLD AIR FORCE STATION, TENNESSEE  
AIR FORCE SYSTEMS COMMAND  
UNITED STATES AIR FORCE**

## NOTICES

When U. S. Government drawings, specifications, or other data are used for any purpose other than a definitely related Government procurement operation, the Government thereby incurs no responsibility nor any obligation whatsoever, and the fact that the government may have formulated, furnished, or in any way supplied the said drawings, specifications, or other data, is not to be regarded by implication or otherwise, or in any manner licensing the holder or any other person or corporation, or conveying any rights or permission to manufacture, use, or sell any patented invention that may in any way be related thereto.

Qualified users may obtain copies of this report from the Defense Technical Information Center.

References to named commercial products in this report are not to be considered in any sense as an endorsement of the product by the United States Air Force or the Government.

This report has been reviewed by the Office of Public Affairs (PA) and is releasable to the National Technical Information Service (NTIS). At NTIS, it will be available to the general public, including foreign nations.

## APPROVAL STATEMENT

This report has been reviewed and approved.



VINCENT CENTONZE, 1st Lt, USAF  
Reentry Systems Division  
Directorate of Aerospace Flight Dynamics Test  
Deputy for Operations

Approved for publication:

FOR THE COMMANDER

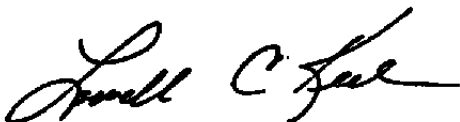

LOWELL C. KEEL, Lt Colonel, USAF  
Director of Technology  
Deputy for Operations

UNCLASSIFIED

SECURITY CLASSIFICATION OF THIS PAGE

REPORT DOCUMENTATION PAGE

|   |   |   |                                      |
|---|---|---|--------------------------------------|
| 1a. REPORT SECURITY CLASSIFICATION<br><b>UNCLASSIFIED</b>   |   | 1b. RESTRICTIVE MARKINGS  |                                      |
| 2a. SECURITY CLASSIFICATION AUTHORITY   |   | 3. DISTRIBUTION/AVAILABILITY OF REPORT<br><br><b>SEE REVERSE OF THIS PAGE.</b>    |                                      |
| 2b. DECLASSIFICATION/DOWNGRADING SCHEDULE   |   |   |                                      |
| 4. PERFORMING ORGANIZATION REPORT NUMBER(S)<br><br><b>AEDC-TR-86-2</b>  |   | 5. MONITORING ORGANIZATION REPORT NUMBER(S)                                       |                                      |
| 6a. NAME OF PERFORMING ORGANIZATION<br><b>Arnold Engineering Development Center</b>   | 6b. OFFICE SYMBOL<br><i>(If applicable)</i><br><b>DOF</b> | 7a. NAME OF MONITORING ORGANIZATION   |                                      |
| 6c. ADDRESS (City, State and ZIP Code)<br><b>Air Force Systems Command<br/>Arnold Air Force Station, TN 37389-5000</b>  |   | 7b. ADDRESS (City, State and ZIP Code)  |                                      |
| 8a. NAME OF FUNDING/SPONSORING ORGANIZATION<br><b>Arnold Engineering Development Center</b>   | 8b. OFFICE SYMBOL<br><i>(If applicable)</i><br><b>DO</b>  | 9. PROCUREMENT INSTRUMENT IDENTIFICATION NUMBER                                   |                                      |
| 8c. ADDRESS (City, State and ZIP Code)<br><b>Air Force Systems Command<br/>Arnold Air Force Station, TN 37389-5000</b>  |   | 10. SOURCE OF FUNDING NOS   |                                      |
| 11. TITLE (Include Security Classification)<br><b>SEE REVERSE OF THIS PAGE.</b>   |   | PROGRAM ELEMENT NO.<br><br><b>65807F</b>  | PROJECT NO.<br><br>                  |
|   |   | TASK NO.<br><br>  | WORK UNIT NO.<br><br>                |
| 12. PERSONAL AUTHOR(S)<br><b>Welsh, C. J. and Centonze, Vincent, 1st Lt, USAF</b>   |   |   |                                      |
| 13a. TYPE OF REPORT<br><b>Final</b>   | 13b. TIME COVERED<br><b>FROM 7/1/84 TO 5/1/85</b>         | 14. DATE OF REPORT (Yr. Mo., Day)<br><b>April 1986</b>                            | 15. PAGE COUNT<br><b>21</b>          |
| 16. SUPPLEMENTARY NOTATION<br><b>Welsh, C. J., Calspan Corp./AEDC Division and Centonze, Vincent, 1st Lt, USAF</b>  |   |   |                                      |
| 17. COSATI CODES  |   | 18. SUBJECT TERMS (Continue on reverse if necessary and identify by block number) |                                      |
| FIELD   | GROUP   | SUB GR  |                                      |
| <b>14</b>   | <b>04</b>   |   |                                      |
|   |   | <b>transparency testing<br/>bird impacts<br/>artificial birds</b>                 |                                      |
| 19. ABSTRACT (Continue on reverse if necessary and identify by block number)<br><br>An analysis was made concerning the use of artificial birds in bird impact testing of aircraft transparencies. Results of this analysis, including impact measurements at a nominal velocity of 500 fps, indicate that the use of artificial birds for impact testing at these conditions is impractical. This follows from the importance and difficulty of simulating the shear strength characteristics of real birds in transparency impacts. |   |   |                                      |
| 20. DISTRIBUTION/AVAILABILITY OF ABSTRACT<br><b>UNCLASSIFIED/UNLIMITED <input type="checkbox"/> SAME AS RPT. <input checked="" type="checkbox"/> DTIC USERS <input type="checkbox"/></b>  |   | 21. ABSTRACT SECURITY CLASSIFICATION<br><br><b>UNCLASSIFIED</b>                   |                                      |
| 22a. NAME OF RESPONSIBLE INDIVIDUAL<br><br><b>W. O. Cole</b>  |   | 22b. TELEPHONE NUMBER<br><i>(Include Area Code)</i><br><b>615-454-7813</b>        | 22c. OFFICE SYMBOL<br><br><b>DOS</b> |

UNCLASSIFIED

SECURITY CLASSIFICATION OF THIS PAGE

3. DISTRIBUTION/AVAILABILITY OF REPORT

Approved for public release; distribution unlimited.

11. TITLE

Aircraft Transparency Testing - Artificial Birds

UNCLASSIFIED

SECURITY CLASSIFICATION OF THIS PAGE

## **PREFACE**

The work reported herein was performed by the Arnold Engineering Development Center (AEDC), Air Force Systems Command (AFSC). The results were obtained by Calspan Corporation, AEDC Division, operating contractor for the aerospace flight dynamics testing facilities at the AEDC, AFSC, Arnold Air Force Station, Tennessee under Project Number CC60VK. The Project Monitor was 1st Lt Vincent Centonze. The research was performed from July 1, 1984 through May 1, 1985, and the manuscript was submitted for publication on November 27, 1985.

## CONTENTS

|                                  | <u>Page</u> |
|----------------------------------|-------------|
| 1.0 INTRODUCTION .....           | 5           |
| 2.0 APPARATUS .....              | 5           |
| 2.1 Test Facility .....          | 5           |
| 2.2 Projectiles and Sabots ..... | 5           |
| 2.3 Test Instrumentation .....   | 6           |
| 3.0 DISCUSSION .....             | 6           |
| 3.1 Types of Impacts .....       | 6           |
| 3.2 Experimental Tests .....     | 7           |
| 4.0 CONCLUDING REMARKS .....     | 9           |
| REFERENCES .....                 | 9           |

## ILLUSTRATIONS

### Figure

|  |    |
|--|----|
| 1. AEDC Bird Impact Range, S3 .....                    | 11 |
| 2. Test Area Arrangement .....                         | 12 |
| 3. Target Plate Installation .....                     | 13 |
| 4. Projectiles Just Prior to Target Plate Impact ..... | 14 |
| 5. Debris Patterns Following Impact .....              | 15 |
| 6. Deformations of Aluminum Target Plates .....        | 16 |

## TABLE

|                       |    |
|-----------------------|----|
| 1. Shot Summary ..... | 17 |
|-----------------------|----|

## 1.0 INTRODUCTION

Over the last several years a concerted effort has been directed toward improving the bird impact resistance characteristics of aircraft transparencies. Ground testing is an important part of this effort in which carcasses of previously killed birds (normally 4-lb chickens) are used in the impact tests of the transparencies. Because of the inhomogeneity of real birds and their irregular geometry, investigators in the past, for example Ref. 1; have examined the use of artificial birds having more desirable features such as a homogeneous material and a simple geometry. Recommendations listed in Ref. 1 include the use of a homogeneous gelatin material with 10-percent porosity as a substitute bird material that is molded in a cylindrical shape having a fineness ratio of two; however, additional experimental tests related to the use of artificial birds were also included in the recommendations of Ref. 1.

A study, including six impact shots made at a nominal velocity of 500 fps, was recently made at AEDC concerning the use of artificial birds, and the purpose of this report is to present the results of that study.

## 2.0 APPARATUS

### 2.1 TEST FACILITY

The Range S3 test unit is comprised of a compressed-air-operated launcher, an X-ray system for measuring bird velocity, and a test stand for placement of the test target. The test unit and test area arrangement are shown in Figs. 1 and 2, and detailed descriptions of the test unit and its capabilities are contained in Ref. 2. The target configuration used in the current test is shown in Fig. 3 and consisted of aluminum (T6-6061) plates bolted to a 1-in.-thick steel support plate with a 16-in.-diam opening. The support plate was adjusted transversely to the flight direction to position the center of the 16-in.-diam opening on the gun centerline.

### 2.2 PROJECTILES AND SABOTS

Projectiles launched in the current tests were either 4-lb chicken carcasses or artificial birds of a 4-in.-diam cylindrical shape with a nominal fineness ratio of two. The artificial birds were fabricated of a gelatin material using a molding process consistent with the recommendations of Ref. 1. The nominal density of the artificial birds was  $0.92 \text{ gm/cm}^3$ , and the corresponding longitudinal density gradient was within two percent of the mean density. The 4-lb required weight was obtained by small adjustments to the length of the artificial birds. The chicken carcasses were of chickens previously asphyxiated, quick frozen, and stored at  $0^\circ\text{F}$ . Prior to testing, a carcass was thawed in still air at room temperature ( $75^\circ\text{F}$ ) for approximately 24 hours or until the body cavity temperature was  $70 \pm 10^\circ\text{F}$ . Small adjustments

to the bird carcass weight were required to achieve the 4-lb weight requirement and were accomplished by clipping carcass appendages.

The real and artificial birds were mated to the launch tube using sabots fabricated of either polyethylene foam or balsa wood. Separation of the bird from the sabot after launch was accomplished through use of the tapered and grooved conic sabot stripper attached directly to the vent section of the launch tube (Fig. 2). As the launch package entered the sabot stripper, the sabot velocity gradually decreased to zero by the shearing of the sabot material, permitting the bird to exit in free flight.

### 2.3 TEST INSTRUMENTATION

Bird position and orientation prior to impact were monitored using three 105-kv X-ray shadowgraph units mounted on an instrumentation cart positioned along the flight path (Fig. 2). The X-ray stations were nominally 3.5 ft apart with the first station located approximately 5 ft from the muzzle of the sabot stripper. Each X-ray station was activated when the bird severed a 24-gage copper wire in an electrical breakwire system. Each X-ray pulser also triggered a chronograph system providing elapsed time measurements between stations. Bird velocity was computed from displacement-time measurements obtained from the in-flight X-rays and the chronograph system.

Photographic documentation of an impact event and the resulting debris patterns was recorded using 16-mm motion picture cameras (Hycam<sup>®</sup> Model No. 41-004) operating at approximately 5000 frames/sec.

## 3.0 DISCUSSION

### 3.1 TYPES OF IMPACTS

A basic relationship in impact testing is one in which the momentum of the projectile prior to impact with a target is equated to the total impulse required in stopping the projectile:

$$(mv)_i = F_{ef} \cdot \Delta t$$

where



$(mv)_i$  = projectile momentum prior to impact

$m$  = projectile mass

$v$  = projectile velocity

and

$F_{ef} \cdot \Delta t$  = total impulse required in stopping the projectile

$F_{ef}$  = effective force during the impact event

$\Delta t$  = time of the impact event

It is important to observe that in a transparency impact test the effective shear strength of the projectile (real birds) is normally much less than the allowable shear stress of the transparency; hence, in such a test,  $\Delta t$  can be defined approximately by the crush time of the projectile (the time between the impacts of its leading and trailing edges) and is proportional to the shear strength of the projectile material. In turn,  $F_{ef}$ , the primary parameter in determining the extent of transparency damage, is inversely proportional to  $\Delta t$  for a given total impulse. It follows that the damage in a transparency impact is very dependent on the shear characteristics of the projectile material.

The importance of the projectile material strength, including any artificial bird material that might be selected, tends to be unique to this type of impact testing. For example, in hypervelocity impacts, the impact stresses generated are normally many times larger than the allowable stresses of the projectile materials; hence,  $\Delta t$  tends to be insensitive to projectile material changes. Furthermore, in many low-speed impacts, in which the projectile material allowable shear stress can be appreciably higher than that of the target material,  $\Delta t$  again tends to be insensitive to projectile material changes.

### 3.2 EXPERIMENTAL TESTS

Because of both the importance of the projectile material strength in transparency impact tests, as discussed in Section 3.1, and the inhomogeneity of real birds, it was questionable that an artificial bird material, as defined in Ref. 1, could adequately simulate the impact characteristics of a real bird. This is particularly true considering the wide range of test conditions normally associated with transparency tests. Thus, tests were designed to maximize

the capability of detecting differences in projectile material characteristics. The tests used 4-lb birds impacting high-strength aluminum plates (normal to bird flight direction) with the impact events monitored through the use of high-speed movie cameras. Such tests permitted  $\Delta t$  (crush time of bird) and the resulting debris patterns to be obtained from an examination of the movie film, and the maximum permanent deformation (flight direction) of the target plate to be obtained from posttest measurements.

All shots were made at velocities near 500 fps and are summarized in Table 1. The  $\Delta t$  values, obtained from a frame-by-frame examination of the movie film, indicate that the real bird behaved as a near-zero-shear material; that is,  $\Delta t$  was approximately equal to the length of the bird divided by the impact velocity. The  $\Delta t$  of the gelatin bird was about 30 percent larger than that of the real bird. The difference in the lengths of the gelatin bird and the real bird only accounts for about one third of the difference observed between the  $\Delta t$  values. It follows that the  $\Delta t$  measurements indicate the shear strength of the gelatin bird was appreciably larger than the strength of a real bird. Photographs of an artificial bird and a real bird just prior to impact are shown in Fig. 4. Photographs of bird debris following impact of the leading edge of the birds are shown in Fig. 5. The large differences in the debris patterns shown in Fig. 5 indicate, again, that the shear strength of the gelatin bird is appreciably larger than that of a real bird. A photograph showing representative differences in the deformations of aluminum plates between real and artificial bird impacts is presented in Fig. 6. Corresponding deformation measurements listed in Table 1 for the 0.25-in.-thick aluminum target plates indicate that the maximum permanent deformation (in the flight direction) of a target plate from a real bird impact was about 35 percent larger than that from the gelatin bird. It is important to observe that all three types of measurements,  $\Delta t$ , debris patterns, and plate deformation, are consistent in indicating appreciable differences in the shear characteristics of the gelatin bird material from that of a real bird.

The present measurements, in conjunction with the importance of projectile material strength noted in Section 3.1, indicate that it is impractical to use current homogeneous substitute materials in impact testing of transparencies. Further, the detected differences in the impact characteristics of real and artificial birds at 500 fps may not be representative of differences that could occur at other test conditions. In addition, experience in impact testing of transparencies at AEDC indicates that sanitation and cleanup concerns attributed to the use of real birds are insignificant.

#### 4.0 CONCLUDING REMARKS

An analysis was made concerning the use of artificial birds in impact testing of aircraft transparencies, including impact tests made at a nominal velocity of 500 fps. Significant differences in the impact behavior between real and artificial birds were measured, and the results of the analysis indicate that the use of artificial birds for impact testing at these conditions is impractical. This follows from the importance and the difficulty of simulating the shear strength characteristics of real birds in this type of an impact.

#### REFERENCES

1. Challita, Antonios. "Validation of a Bird Substitute for Development and Qualification of Aircraft Transparencies." AFWAL-TR-80-3098, (AD-A097 736), October 1980.
2. Sanders, E. J. "The von Kármán Gas Dynamics Facility Range S3 - Description and Capabilities." AEDC-TR-76-9, (AD-B008983L) January 1976.

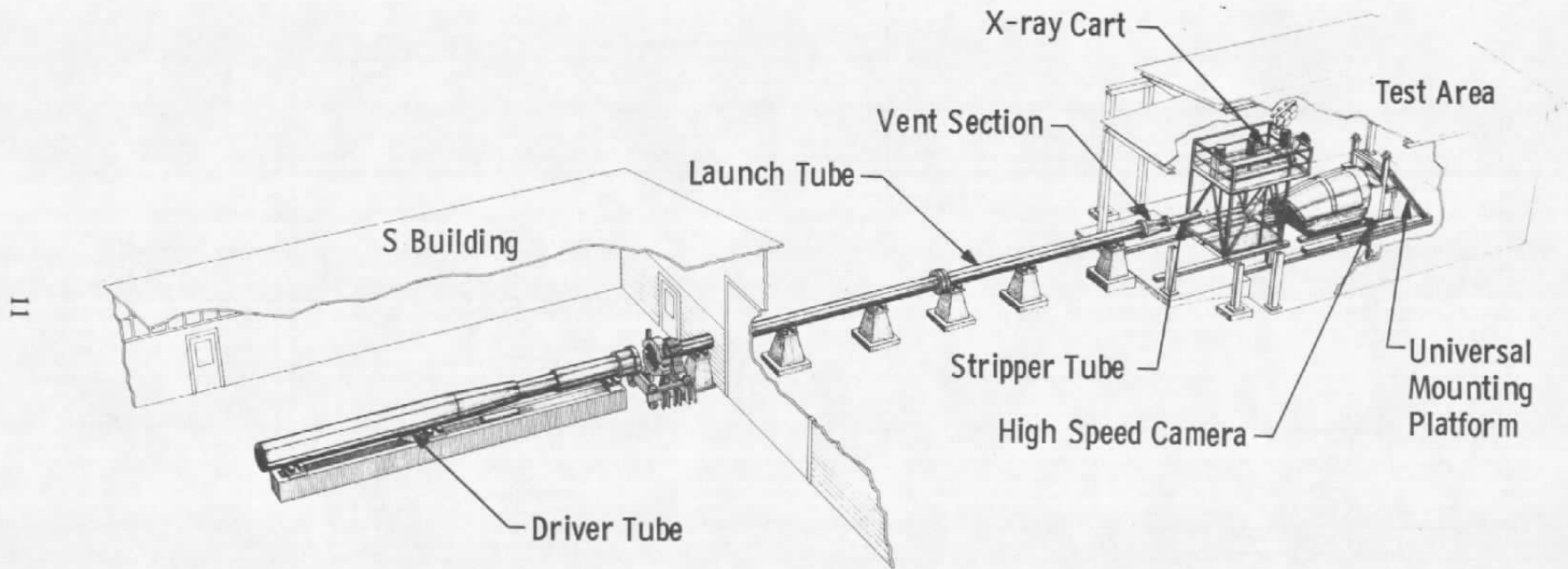

Figure 1. AEDC Bird Impact Range, S3.

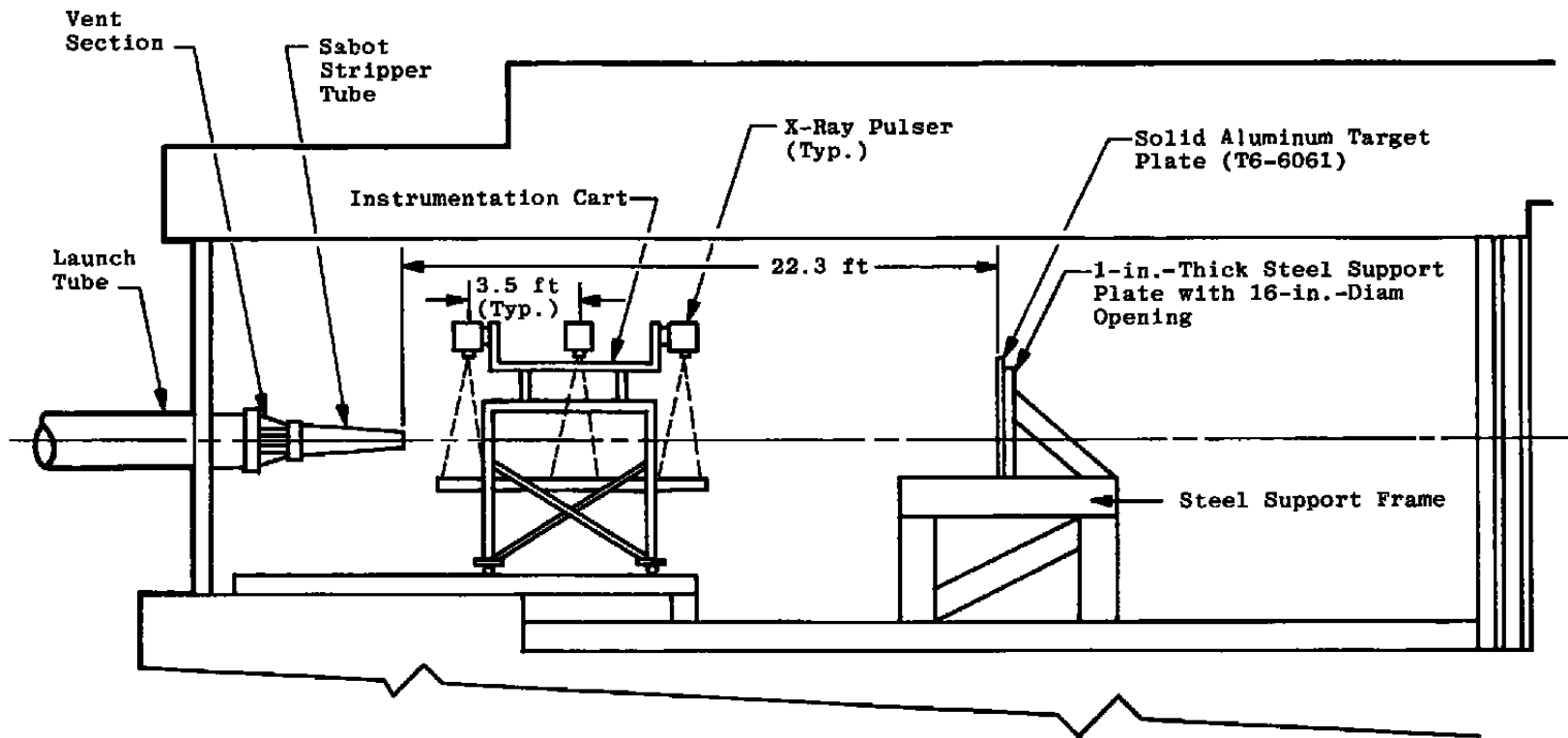

Figure 2. Test area arrangement.

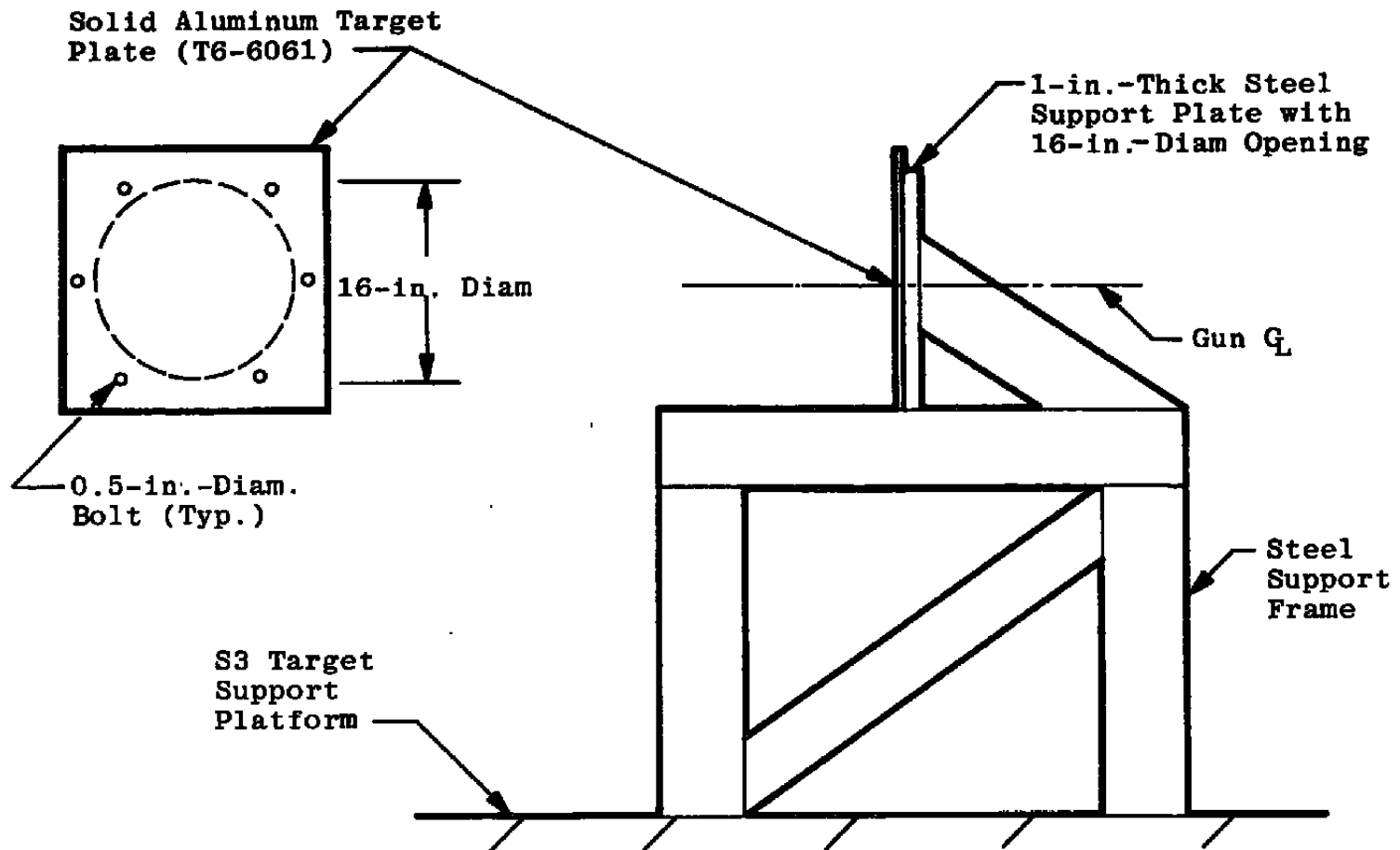
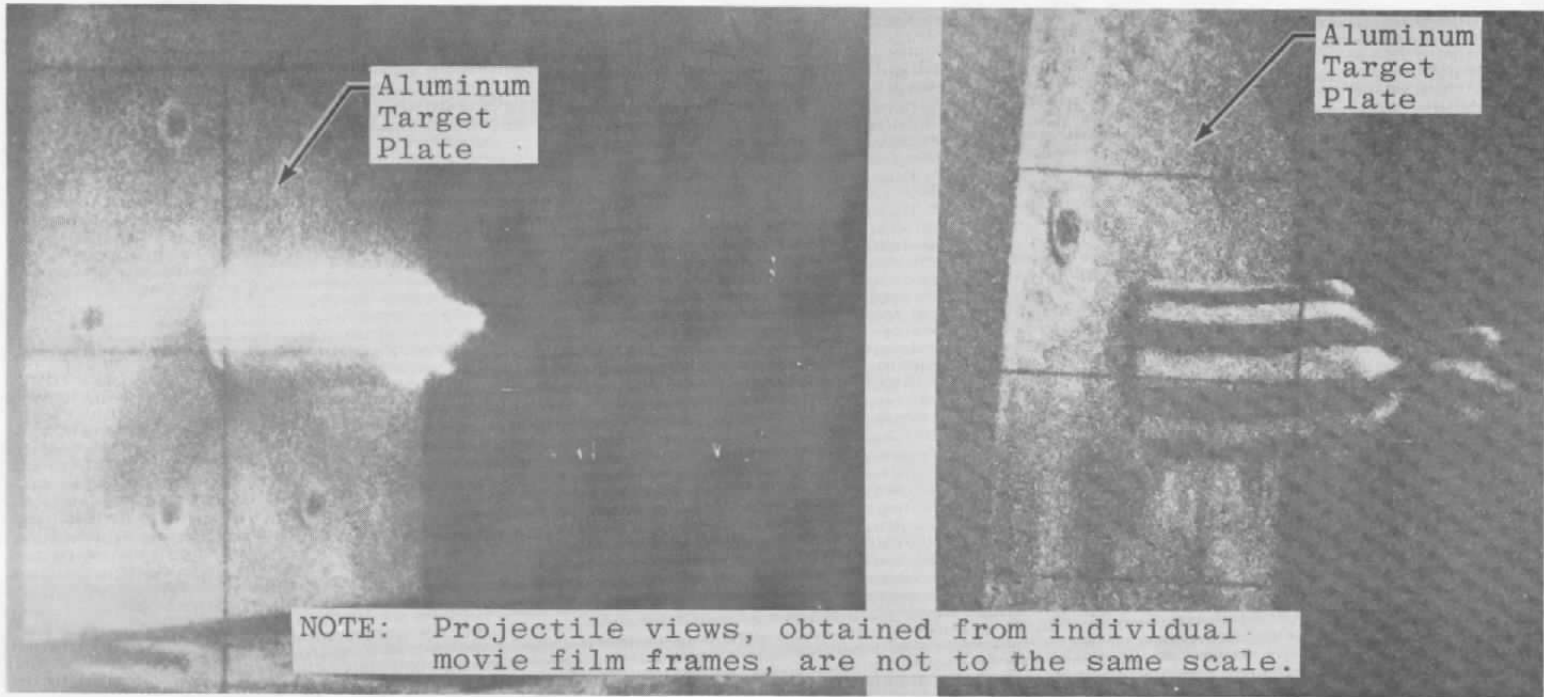

Figure 3. Target plate installation.



**a. Gelatin bird**  
(in white taffeta bag)

**b. Real bird**  
(in painted taffeta bag)

**Figure 4. Projectiles just prior to target plate impact.**

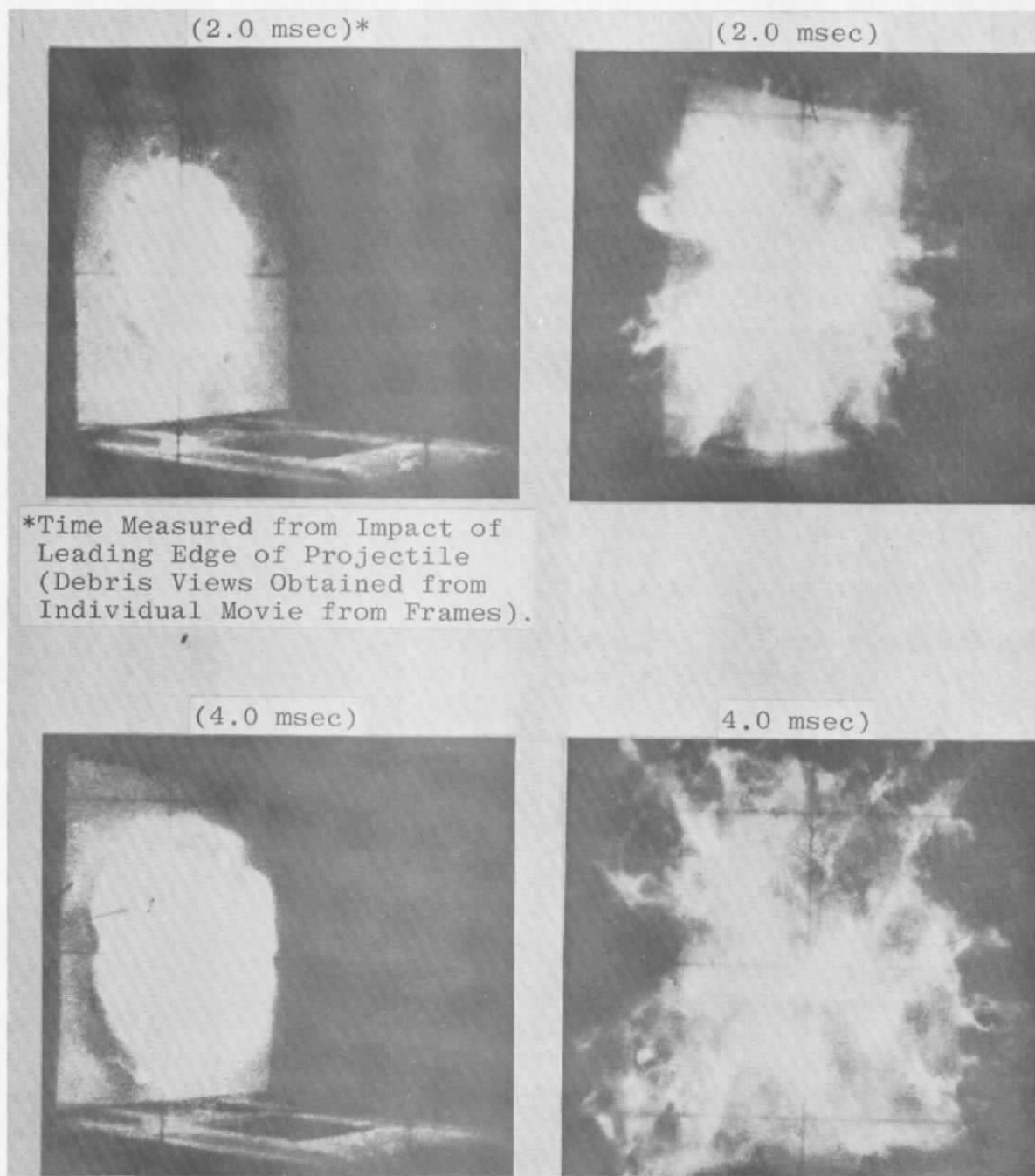

\*Time Measured from Impact of  
Leading Edge of Projectile  
(Debris Views Obtained from  
Individual Movie from Frames).

a. Gelatin bird

b. Real bird

Figure 5. Debris patterns following impact.



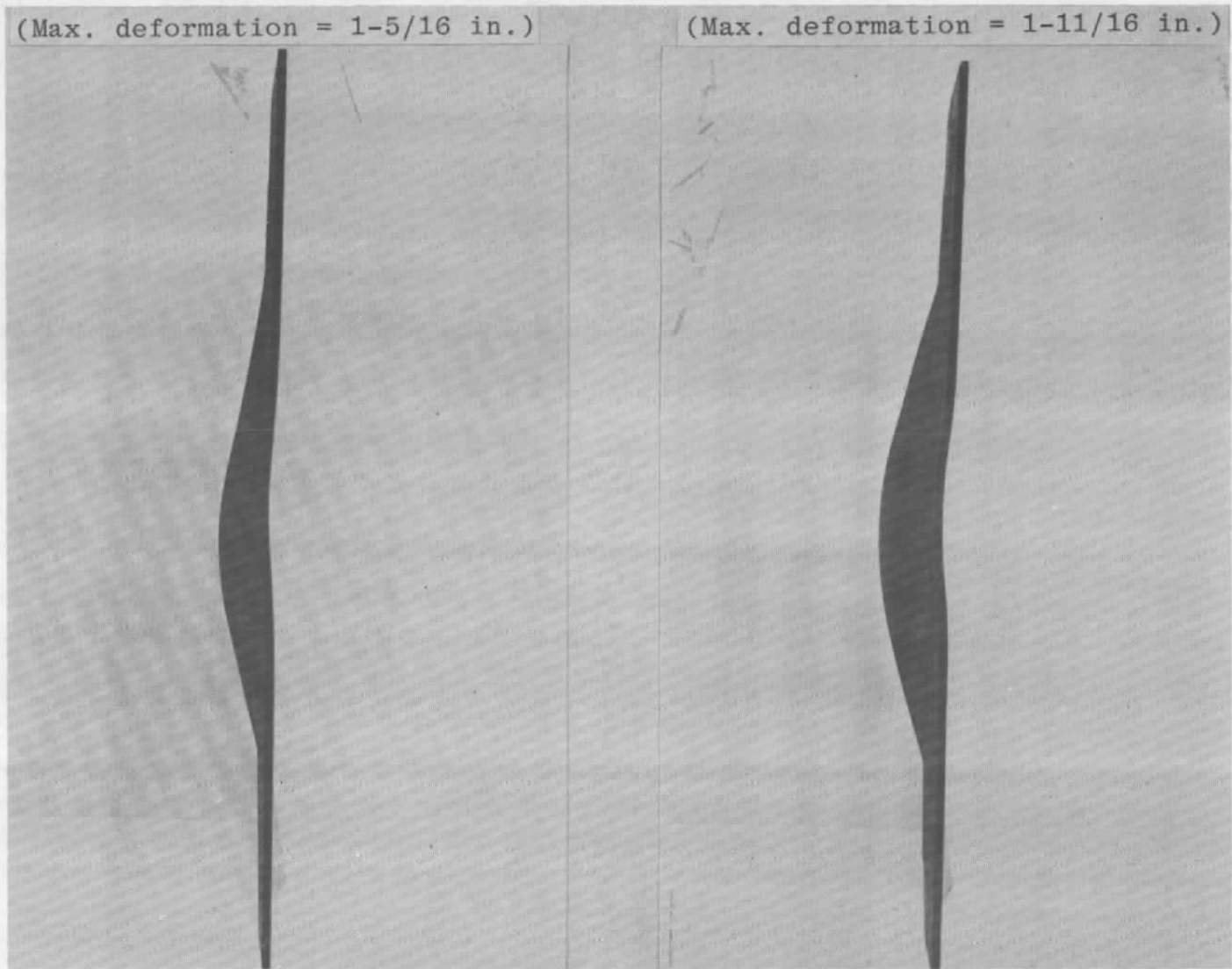

a. Gelatin bird, 499 fps

b. Real bird,  $V = 494$  fps

Figure 6. Deformations of aluminum target plates.

**Table 1. Shot Summary**

| Shot | Projectile Material | Length <sup>†</sup> of Projectile in. | Velocity fps | Target <sup>††</sup> Plate Thickness, in. | Maximum <sup>†††</sup> Deflection of Target Plate, in. |
|------|---------------------|---------------------------------------|--------------|---|--|
| 1    | Gelatin             | 8.34                                  | 471          | 0.25                                      | 1 3/16   |
| 2    | Chicken             | 7.67                                  | 478          | 0.25                                      | 1 5/8  |
| 3    | Gelatin             | 8.52                                  | 497          | 0.25                                      | 1 1/4  |
| 4    | Chicken             | 7.75                                  | 494          | 0.25                                      | 1 11/16  |
| 5    | Gelatin             | 8.52                                  | 499          | 0.25                                      | 1 5/16   |
| 6    | Chicken             | 7.79                                  | 511          | 0.50                                      | 13/16  |

† As measured at third X-ray station

†† All target plates were of T6061-T6 aluminum alloy

††† Measured in flight direction

NOTES: A detailed examination (frame-by-frame) of the movie film for the series of shots indicates a  $\Delta t$  equivalent to 6-1/2 frames for the real chicken and to 8-1/2 frames for the gelatin bird. Frame time interval was nominally 0.2 msec.

All projectiles, gelatin or chicken, were adjusted to 4 lb.

Gelatin bird diameter was 4 in., and nominal maximum chicken diameter was 5-1/4 in.