

UNCLASSIFIED

AD NUMBER

AD383442

CLASSIFICATION CHANGES

TO: unclassified

FROM: secret

LIMITATION CHANGES

TO:  
Approved for public release, distribution  
unlimited

FROM:  
Controlling DoD Organization: Defense  
Advanced Research Projects Agency,  
Arlington, VA.

AUTHORITY

DARPA ltr, 18 Feb 1993; DARPA ltr, 18 Feb  
1993

THIS PAGE IS UNCLASSIFIED

# **SECURITY**

---

# **MARKING**

**The classified or limited status of this report applies to each page, unless otherwise marked.**

**Separate page printouts MUST be marked accordingly.**

---

**THIS DOCUMENT CONTAINS INFORMATION AFFECTING THE NATIONAL DEFENSE OF THE UNITED STATES WITHIN THE MEANING OF THE ESPIONAGE LAWS, TITLE 18, U.S.C., SECTIONS 793 AND 794. THE TRANSMISSION OR THE REVELATION OF ITS CONTENTS IN ANY MANNER TO AN UNAUTHORIZED PERSON IS PROHIBITED BY LAW.**

**NOTICE: When government or other drawings, specifications or other data are used for any purpose other than in connection with a definitely related government procurement operation, the U. S. Government thereby incurs no responsibility, nor any obligation whatsoever; and the fact that the Government may have formulated, furnished, or in any way supplied the said drawings, specifications, or other data is not to be regarded by implication or otherwise as in any manner licensing the holder or any other person or corporation, or conveying any rights or permission to manufacture, use or sell any patented invention that may in any way be related thereto.**

SECRET

AD 383442

RESEARCH PAPER P-315

AD 383442

AIR-SOWN MINES FOR THE MASSIVE BARRIER (U)

Val L. Fitch  
Leon Lederman

August 1966

ADDC  
RECEIVED  
AUG 29 1967  
MILITARY



INSTITUTE FOR DEFENSE ANALYSES  
JASON DIVISION

SECRET

Log No. IDA/HQ-66-5197  
Copy of 100

*The Institute for Defense Analyses produces three kinds of publication for distribution, entitled Report, Study, and Research Paper.*

*A Report embodies the results of a major research project undertaken by IDA and is intended to be an authoritative contribution on its subject.*

*A Study is a less formal document and less comprehensive in scope than a Report. It may be the result of a smaller and more narrowly defined research project or it may be a supporting technical paper prepared in connection with a major project.*

*A Research Paper represents the work of one or more named authors but is subject to review comparable to that for publication in a professional journal.*

This material contains information affecting the national defense of the United States within the meaning of the Espionage Laws (Title 18, U. S. C., Sections 793 and 794), the transmission or revelation of which in any manner to an unauthorized person is prohibited by law.

GROUP-3  
DOWNGRADED AT 12 YEAR INTERVALS;  
NOT AUTOMATICALLY DECLASSIFIED

**SECRET**

RESEARCH PAPER P-315

**AIR-SOWN MINES FOR THE MASSIVE BARRIER**

Val L. Fitch  
Leon Lederman

Published May 1967



INSTITUTE FOR DEFENSE ANALYSES  
JASON DIVISION

Contract DAHC-15 67-C-0011  
Task T-36

**SECRET**

**UNCLASSIFIED**

**CONTENTS**

INTRODUCTION . . . . .	1
PENCIL MINES . . . . .	2
Pencil Mine, Mark I . . . . .	2
Antitruck Version . . . . .	6
Activator Variations . . . . .	6
Plastic Casing Alternatives . . . . .	6
Counter-Countermeasures . . . . .	7
SUMMARY . . . . .	7

**UNCLASSIFIED**

# SECRET

## AIR-SOWN MINES FOR THE MASSIVE BARRIER

V. L. Fitch<sup>1</sup> and L. Lederman<sup>2</sup>

### I. INTRODUCTION

In the course of many discussions on the use of barriers in Southeast Asia, the Summer Study Group<sup>3</sup> was impressed by the fact that only a very small variety of mines was available for laying from the air. Not only is the variety limited, but the targets for which the mines have been designed reflect more the needs of the classically European type of war than those in Southeast Asia. Clearly, the effectiveness of a minefield depends in a crucial way upon its opposition to a determined penetration effort. For an air-supported and sensor-equipped barrier, this aspect is even more important and the success of the entire program rests on the relative difficulty of sweeping the trails and roads clear of such mines. The available (or soon to be available) mines that are especially suited for operations in Vietnam are the gravel and dragon's tooth types. These, with minor modifications, undoubtedly will be very effective against traffic on narrow trails or in the brush, provided that they prove to be adequately resistant to water, etc. But these mines are relatively conspicuous on well-traveled trails and roads, and they are easily swept away.

It has been suggested, for example, that the enemy could establish a string of road-sweeping personnel along the line

---

<sup>1</sup>Princeton University, Princeton, N.J.

<sup>2</sup>Nevis Laboratories, Irvington-on-Hudson, N.Y.

<sup>3</sup>For list of participants, see IDA Study S-255.

SECRET

## SECRET

of travel, with each man being responsible for keeping his section of a few tens of meters spotless. If we assume the enemy has successfully come through the transient period, then this could be a very effective countermeasure, unless the mines are made much more difficult to detect. We discuss here a series of air-sown mines designed to complement the gravel mine and to be sown densely along wider trails and truck roads.

### II. PENCIL MINES

This series of devices is based on the idea that one can make a pencil-shaped projectile, which would be air-dropped and fin-stabilized. The device should penetrate to a predetermined depth, so that in most cases only about a half-centimeter of plunger-activator projects to the trail surface. The depth of penetration can be controlled by the drop altitude and by aerodynamic design.

We offer a moderately detailed design of one form of pencil mine and then outline the variations we believe should be combined to sow this kind of terrain (i.e., jungle) effectively.

#### A. PENCIL MINE, MARK I

##### 1. General Configuration, Firing Mechanism

The design proposed here is intended only to convey the concept of the device and to elaborate on the features to be desired. Undoubtedly, much better ways can be found for implementing the weapon. A sketch of a possible device is shown in Figure 1.

The following considerations have been applied in an effort to see if such a device is technically possible. Since it is intended that the casing of the device function as a gun barrel, the permissible internal pressures are set by the barrel

SECRET



**SECRET**

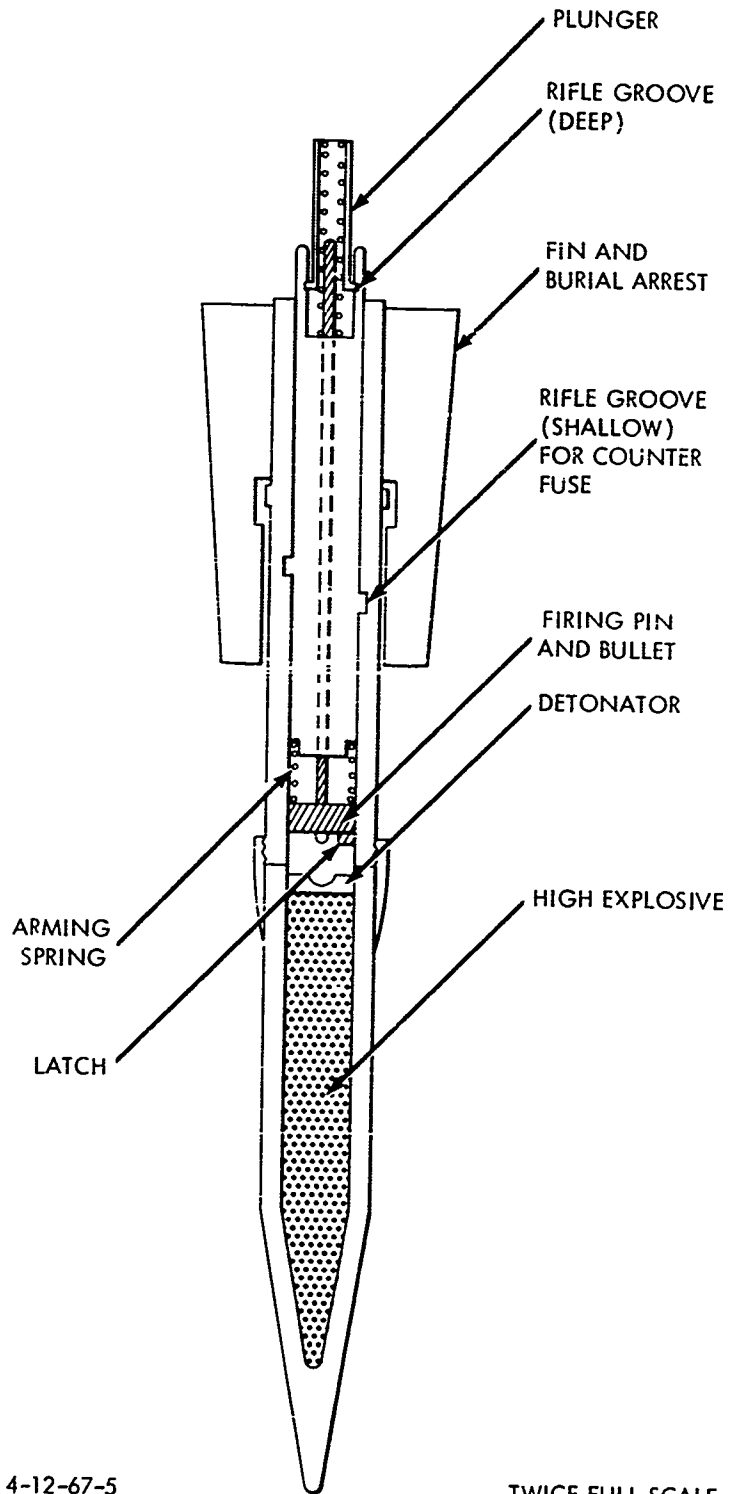

4-12-67-5

TWICE FULL SCALE

FIGURE 1. Proposed Possible Basic Design of Air-Sown Pencil Mine

**SECRET**

## SECRET

dimensions and the tensile strength of the steel used in fabrication. In particular,

$$P_p = T \frac{\delta}{r}$$

where  $P_p$  is the peak pressure,  $T$  is the tensile strength of steel,  $\delta$  is the barrel thickness, and  $r$  is the mean radius of the barrel. The average pressure required to produce a muzzle velocity  $v$  is

$$p = \frac{mv^2}{2\pi sr^2}$$

where  $m$  is the mass of the projectile and  $s$  is the barrel length.

Equating average pressure and peak pressure, we get

$$sr\delta = \frac{mv^2}{2\pi T}$$

The tensile strength of steel ranges from 30,000 to 3,000,000 lb/in.<sup>2</sup>

With

$$v = 3 \times 10^4 \text{ cm/sec}$$

$$m = 2 \text{ grams}$$

$$T = 3 \times 10^4 \text{ lb/in.}^2 \approx 2 \times 10^9 \text{ dynes/cm}^2$$

$$sr\delta = 15 \times 10^{-2} \text{ cm}^3$$

If  $\delta = 1/32$  in. and  $r = 1/8$  in. then

$$s \approx 2.5$$

## SECRET

## SECRET

Not more than two inches of barrel would be necessary to hold the required powder. In short, a device with a casing dimension of the order of 3/8-in. outside diameter, 1/4-in. to 5/16-in. inside diameter, and 4-1/2-in. length will provide a barrel of requisite strength and length.

### 2. Ballistics and Penetration

The pencil mine is equipped with a fin system to stabilize its fall, and this fin system can be made capable of being bent so as to control the penetration. For example, if the lower sections of the fins are free to deflect when the resistance reaches some critical value, then the cross-sectional area would increase by a large factor and bring the device to a sudden stop. This ability should be largely independent of the soil consistency, and it should minimize the crater aspect. Again, if there is some knowledge of the general penetrability in various areas, the altitude of the drop can be suitably tailored. Clearly, some simple experiments are called for here.

At the present time, the foliage penetration factors are unknown. The earth penetration has been estimated only roughly for sample designs. But it is clear that, by varying the aerodynamics in a trivial way, one can tailor the devices to suit different surface conditions or to render the device relatively insensitive to variations in terrain.

### 3. Counteractivator

The activator is a spring-loaded pin which causes a coupling rod to rotate and advance several millimeters per activation. This resembles the action of a ball point pen, with the activator pin returning to its original position each time.

In the example sketched here, the advance of the activator compresses the firing spring, which progressively arms a firing pin. At the predetermined clink, the spring is released and

SECRET

## SECRET

Not more than two inches of barrel would be necessary to hold the required powder. In short, a device with a casing dimension of the order of 3/8-in. outside diameter, 1/4-in. to 5/16-in. inside diameter, and 4-1/2-in. length will provide a barrel of requisite strength and length.

### 2. Ballistics and Penetration

The pencil mine is equipped with a fin system to stabilize its fall, and this fin system can be made capable of being bent so as to control the penetration. For example, if the lower sections of the fins are free to deflect when the resistance reaches some critical value, then the cross-sectional area would increase by a large factor and bring the device to a sudden stop. This ability should be largely independent of the soil consistency, and it should minimize the crater aspect. Again, if there is some knowledge of the general penetrability in various areas, the altitude of the drop can be suitably tailored. Clearly, some simple experiments are called for here.

At the present time, the foliage penetration factors are unknown. The earth penetration has been estimated only roughly for sample designs. But it is clear that, by varying the aerodynamics in a trivial way, one can tailor the devices to suit different surface conditions or to render the device relatively insensitive to variations in terrain.

### 3. Counteractivator

The activator is a spring-loaded pin which causes a coupling rod to rotate and advance several millimeters per activation. This resembles the action of a ball point pen, with the activator pin returning to its original position each time.

In the example sketched here, the advance of the activator compresses the firing spring, which progressively arms a firing pin. At the predetermined clink, the spring is released and

SECRET

## SECRET

the pin strikes the detonator. Clearly, the advance pitch and spring tensions must be correlated. Other desirable features, not discussed here, are: (1) a "safety" feature, which is released upon impact; (2) a delay feature, which would counteract the steel-soled boot; and (3) a deactivation device with a live period whose duration is months.

### B. ANTITRUCK VERSION

The device sketched in Figure 1 can be scaled up slightly so as to be effective against truck tires. We estimate that an increase in projectile mass by a factor of 5 (i.e., to 10 g) would be all that is required. For these larger devices, the counteractivator would be unnecessary, provided they are sown simultaneously with the pencil mine described above.

### C. ACTIVATOR VARIATIONS

Some fraction of the devices described above should be equipped with alternative triggering modes, to make countermeasures more difficult. One of these could be a simple spring wire, which would be pushed horizontally by a man's foot moving in a shuffling gait. This trigger can be designed to release the latch that frees the now pre-armed firing spring. Another mode involves a short (about 6-in.) length of wire, ending in a barbed tetrahedron which is designed to catch on a boot or sandal. This provides a fractional second of delay before firing, and it is not set off by flailing devices.

### D. PLASTIC CASING ALTERNATIVES

The system should include an all-plastic component, which would not be detected by a mine detector and which would in fact make mine detection or bayonet probing very hazardous. Effectively, this is the gravel mine in a different format. We propose that the high explosive be contained in a very hard

SECRET

## SECRET

plastic projectile, having the approximate shape and size of a cigar and, again, fin stabilized. This can be weighted by a lead-plastic emulsion whose conductivity is very low and whose density is about six. (The weight is an essential consideration for earth penetration.) In this version, we suggest that the charge be made large (at least 20 g of high explosive) and that the activator be a bulb of lead azide stabilized by Freon gel, as in the gravel devices.

### E. COUNTER-COUNTERMEASURES

A general characteristic of this system is the pock-marking of the terrain. After the transient effect has died away, it would be useful to include ten-penny nails along with the mines. These could make holes and give mine detection signals at a rate of 1000 pulse alarms per mine.

### III. SUMMARY

All of the suggested devices require some engineering design and prototype testing. They are not in or near the "current inventory." On the other hand, we believe that the entire air-sown barrier concept rests on the production of such devices, and we urge that a very high priority be given to their implementation within any barrier program.

The object of this study is to produce a system of cheap, small devices that provides an interlocking variety and makes penetration and sweeping extremely difficult. It is assumed that massive sweeping efforts involving heavy rollers, explosives, etc. bring air response and reflect the fact that an infiltration trail has become an overt invasion route.

SECRET

Secret

Security Classification

DOCUMENT CONTROL DATA - R & D		
<i>(Security classification of title, body of abstract and indexing annotation must be entered when the overall report is classified)</i>		
1. ORIGINATING ACTIVITY (Corporate author) Institute for Defense Analyses 400 Army-Navy Drive Arlington, Virginia 22202		2a. REPORT SECURITY CLASSIFICATION Secret
		2b. GROUP 3
3. REPORT TITLE  Air-Sown Mines for the Massive Barrier (U)		
4. DESCRIPTIVE NOTES (Type of report and inclusive dates)		
5. AUTHOR(S) (First name, middle initial, last name)  Val L. Fitch and Leon Lederman		
6. REPORT DATE Date of Publication: May 1967	7a. TOTAL NO. OF PAGES 7	7b. NO. OF REFS None
8a. CONTRACT OR GRANT NO. DAHC-15 67-C-0011	9a. ORIGINATOR'S REPORT NUMBER(S) Research Paper P-315	
b. PROJECT NO.	9b. OTHER REPORT NO(S) (Any other numbers that may be assigned this report)	
c.		
d.		
10. DISTRIBUTION STATEMENT		
11. SUPPLEMENTARY NOTES		12. SPONSORING MILITARY ACTIVITY Advanced Research Projects Agency Washington, D.C.
13. ABSTRACT  A discussion of a series of air-sown mines designed to complement the use of gravel mines and to be sown densely along wider trails and roads is presented. The basic design is a pencil-shaped, fin-stabilized device which would be capable of soil penetration to a predetermined depth, so that a plunger-activator projects just slightly above the trail surface. The objective is to produce a <u>system</u> of cheap, small devices that would present a formidable barrier to infiltration and would be difficult to counter. (S)		

DD FORM 1473  
1 NOV 65

Secret

Security Classification